



# Installation and Operations Manual

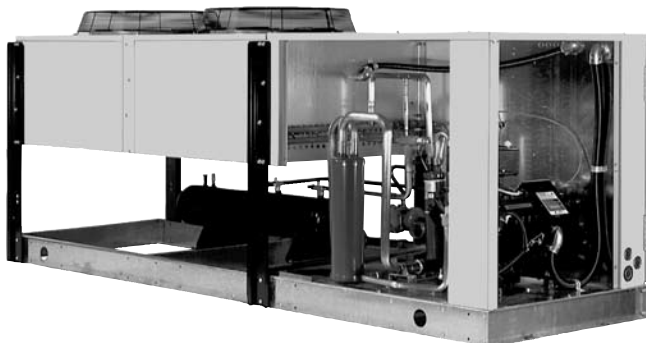
**H-IM-CU**

**August 2008**

**Part No. 25008101**

Replaces None. Information formerly included in H-IM-64L.

## Condensing Units



### Table of Contents

General Safety Information.....	2
Inspection .....	2
Warranty Statement .....	2
Space and Location Requirements .....	3
Remote and Water Cooled Condensing Units Requirements .....	4
City & Tower Water Connections.....	4
Condensing Unit Rigging and Mounting .....	5
Head Pressure Control.....	6
Refrigerant Oils.....	7
Phase Loss Monitor.....	8
Recommended Refrigerant Piping Practices .....	8
Refrigeration Pipe Supports .....	8
Suction Lines.....	8
Liquid Lines .....	9
Hot Gas Defrost Systems .....	9
Unit Cooler Piping.....	10
Line Sizing Tables .....	10-13
Evacuation and Leak Detection .....	14
Refrigerant Charging Instructions.....	14
Field Wiring.....	14
Check Out and Start Up .....	15
Operational Check Out.....	16
System Balancing - Compressor Superheat.....	16
General Sequence of Operation .....	17
Electric Defrost Troubleshooting.....	17
System Troubleshooting Guide.....	18
Preventive Maintenance Guidelines.....	19
Typical Wiring Diagrams .....	20-23
InterLink™ Replacement Parts .....	24

## General Safety Information

1. Installation and maintenance to be performed only by qualified personnel who are familiar with this type of equipment.
2. Some units are pressurized with dry air or inert gas. All units must be evacuated before charging the system with refrigerant.
3. Make sure that all field wiring conforms to the requirements of the equipment and all applicable national and local codes.
4. Avoid contact with sharp edges and coil surfaces. They are a potential injury hazard.
5. Make sure all power sources are disconnected before any service work is done on units.

**WARNING:** Refrigerant can be harmful if it is inhaled. Refrigerant must be used and recovered responsibly.  
**Failure to follow this warning may result in personal injury or death.**

## Inspection

Responsibility should be assigned to a dependable individual at the job site to receive material. Each shipment should be carefully checked against the bill of lading. The shipping receipt should not be signed until all items listed on the bill of lading have been accounted. Check carefully for concealed damage. Any shortage or damages should be reported to the delivering carrier. Damaged material becomes the delivering carrier's responsibility, and should not be returned to the manufacturer unless prior approval is given to do so. When uncrating, care should be taken to prevent damage. Heavy equipment should be left on its shipping base until it has been moved to the final location. Check the serial tag information with invoice. Report any discrepancies to your Heatcraft Refrigeration Products Sales Representative.

## Warranty Statement

Seller warrants to its direct purchasers that products, including Service Parts, manufactured by SELLER shall be of a merchantable quality, free of defects in material or workmanship, under normal use and service for a period of one **(1) year from date of original installation, or eighteen (18) months from date of shipment** by SELLER, whichever first occurs. Any product covered by this order found to Seller's satisfaction to be defective upon examination at Seller's factory will at SELLER's option, be repaired or replaced and returned to Buyer via lowest common carrier, or SELLER may at its option grant Buyer a credit for the purchase price of the defective article. Upon return of a defective product to SELLER's plant, freight prepaid, by Buyer, correction of such defect by repair or replacement, and return freight via lowest common carrier, shall constitute full performance by SELLER of its obligations hereunder.

SELLER shall have no liability for expenses incurred for repairs made by Buyer except by prior, written authorization. Every claim on account of breach of warranty shall be made to SELLER in writing within the warranty period specified above – otherwise such claim shall be deemed waived. Seller shall have no warranty obligation whatsoever if its products have been subjected to alteration, misuse, negligence, free chemicals in system, corrosive atmosphere, accident, or if operation is contrary to SELLER's or manufacturer's recommendations, or if the serial number has been altered, defaced, or removed.

## MOTOR COMPRESSORS:

Motor compressors furnished by SELLER are subject to the standard warranty terms set forth above, except that motor compressor replacements or exchanges shall be made through the nearest authorized wholesaler of the motor compressor manufacturer (not at SELLER's factory) and no freight shall be allowed for transportation of the motor compressor to and from the wholesaler. The replacement motor compressor shall be identical to the model of the motor compressor being replaced. Additional charges which may be incurred throughout the substitution of other than identical replacements are not covered by this warranty. An optional, non assignable, four (4) year extended compressor warranty may be purchased within the boundaries of the United States of America, its territories and possessions, and Canada. With this extended compressor warranty, replacements are administered by an authorized compressor distributor only. Replacements within the first year of the warranty area available through the distributor; the second through fifth years, the purchaser must submit a proof-of-purchase of a compressor and supply it to Heatcraft Refrigeration Products Warranty Claims for reimbursement.

Seller makes no express warranties except as noted above. All implied warranties are limited to the duration of the Express Warranty. Liability for incidental and consequential damages is excluded.

The forgoing is in lieu of all other warranties, express or implied, notwithstanding the provisions of the uniform commercial code, the Magnuson-Moss Warranty - Federal Trade Commission Improvement Act, or any other statutory or common law, federal or state. SELLER makes no warranty, express or implied, of fitness for any particular purpose, or of any nature whatsoever, with respect to products manufactured or sold by seller hereunder, except as specifically set forth above and on the face hereof. It is expressly understood and agreed that SELLER shall not be liable to buyer, or any customer of buyer, for direct or indirect, special, incidental, consequential or penal damages, or for any expenses incurred by reason of the use or misuse by buyer or third parties of said products. To the extent said products may be considered "consumer products," As defined in Sec. 101 of the Magnuson-Moss Warranty - Federal Trade Commission Improvement Act, SELLER makes no warranty of any kind, express or implied, to "consumers," except as specifically set forth above and on the face hereof.

The following conditions should be adhered to when installing this unit to maintain the manufacturers warranty:

- a) System piping must be in accordance with good refrigeration practices.
- b) Inert gas must be charged into the piping during brazing.**
- c) The power supply to the unit must meet the following conditions:
  - A. Three phase voltages must be +/- 10% of nameplate ratings. Single phase must be within +10% or -5% of nameplate ratings.
  - B. Phase imbalance cannot exceed 2%.
- d) All control and safety switch circuits must be properly connected according to the wiring diagram.
- e) The factory installed wiring and piping must not be changed without written factory approval.
- f) All equipment is installed in accordance with Heatcraft Refrigeration Products specified minimum clearances.

## Space and Location Requirements for Air Cooled Condensing Units and Remote Condensers

The most important consideration which must be taken into account when deciding upon the location of air-cooled equipment is the provision for a supply of ambient air to the condenser, and removal of heated air from the condensing unit or remote condenser area. Where this essential requirement is not adhered to, it will result in higher head pressures, which cause poor operation and potential failure of equipment. Units must not be located in the vicinity of steam, hot air or fume exhausts. Corrosive atmospheres require custom designed condensers.

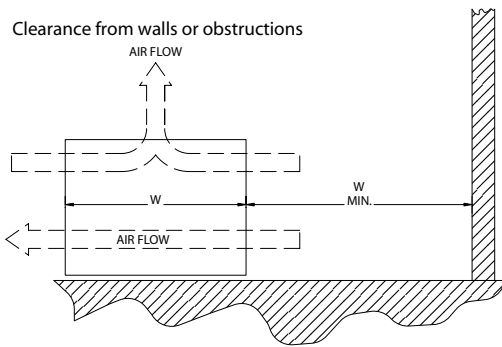
Another consideration which must be taken is that the unit should be mounted away from noise sensitive spaces and must have adequate support to avoid vibration and noise transmission into the building. Units should be mounted over corridors, utility areas, rest rooms and other auxiliary areas where high levels of sound are not an important factor. Sound and structural consultants should be retained for recommendations.

**Figure 1. Space and Location Requirements for Condensing Units**

### Walls or Obstructions

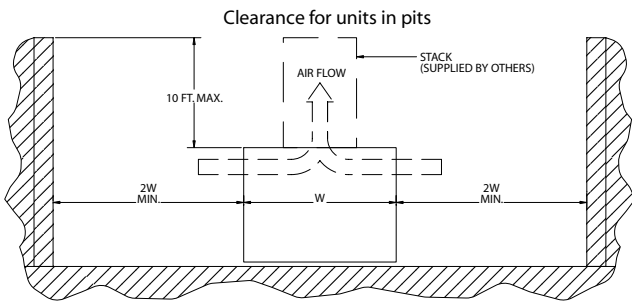
The unit should be located so that air may circulate freely and not be recirculated. For proper air flow and access all sides of the unit should be a minimum of "W" away from any wall or obstruction. It is preferred that this distance be increased whenever possible. Care should be taken to see that ample room is left for maintenance work through access doors and panels. Overhead obstructions are not permitted. When the unit is in an area where it is enclosed by three walls the unit must be installed as indicated for units in a pit.

### Walls or Obstructions for Horizontal Air Flow



### Units in Pits

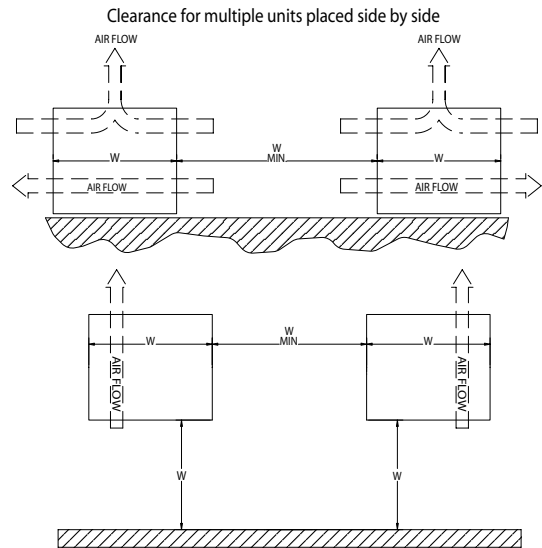
The top of the unit should be level with the top of the pit, and side distance increased to "2W".  
If the top of the unit is not level with the top of pit, discharge cones or stacks must be used to raise discharge air to the top of the pit. This is a minimum requirement.



### Multiple Units

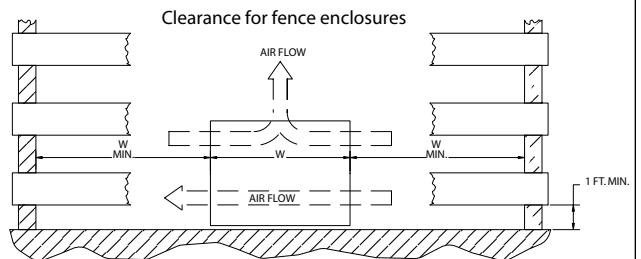
For units placed side by side, the minimum distance between units is the width of the largest unit. If units are placed end to end, the minimum distance between units is 4 feet.

### Multiple Units with Horizontal Air Flow

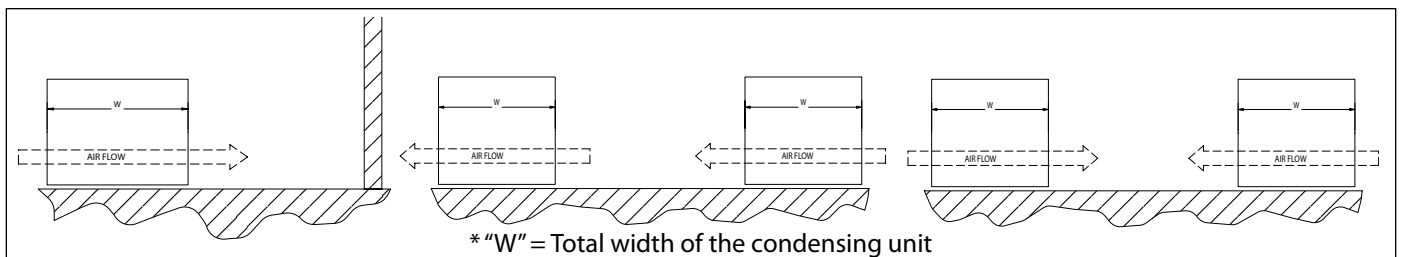


### Decorative Fences

Fences must have 50% free area, with 1 foot undercut, a "W" minimum clearance, and must not exceed the top of unit. If these requirements are not met, unit must be installed as indicated for "Units in pits".



## NOT RECOMMENDED



## Requirements for Remote and Water Cooled Condensing Units

### General Installation

The indoor compressor units are designed to be used with a remote condenser. The water cooled units are similar, except that they have an integral water cooled condenser. Inlet and outlet water connections are to be made in the field. On units having a compressor water jacket, incoming water shall be routed through the jacket prior to entering the condenser. For cleaning purposes, condenser end plates can be removed to give access to the water tubes. Cleaning is accomplished by a simple spiral tool powered by an ordinary electric drill. During installation, allow space for cleaning the condenser. Commercial equipment of this type is intended for installation by qualified refrigeration mechanics.

### Typical Arrangements

Diagram 1 illustrates a typical piping arrangement involving a remote condenser located at a higher elevation, as commonly encountered when the condenser is on a roof and the compressor and receiver are on grade level or in a basement equipment room.

In this case, the design of the discharge line is very critical. If properly sized for full load condition, the gas velocity might be too low at reduced loads to carry oil up through the discharge line and condenser coil. Reducing the discharge line size would increase the gas velocity sufficiently at reduced load conditions; however, when operating at full load, the line would be greatly undersized, and thereby creating an excessive refrigerant pressure drop. This condition can be overcome in one of two of the following ways:

1. The discharge line may be properly sized for the desired pressure drop at full load conditions and an oil separator installed at the bottom of the trap in the discharge line from the compressor.

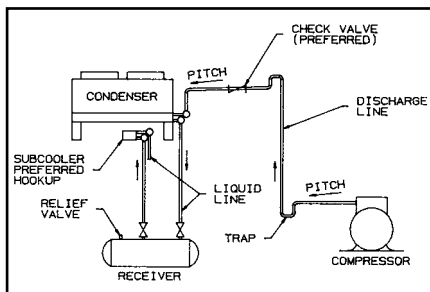


Diagram 1

2. A double riser discharge line may be used as shown in Diagram 2. Line "A" should be sized to carry the oil at minimum load conditions and the line "B" should be sized so that at the full load conditions both lines would have sufficient flow velocity to carry the oil to the condenser.

### Water Regulating Valve

Using this control on the water cooled condensing units, the head pressure can be maintained by adjusting the flow of water through the condenser section. This type control is most often located on the water entering side of the condenser and is regulated by the refrigerant condensing pressure.

### Subcooler

Diagrams 1 and 2 below show typical subcooler piping. Diagram 1 is the preferred connection with receiver as it provides maximum subcooling. Diagram 2 may be used if the receiver is located far from the condenser.

Notes:

1. All oil traps are to be as short in radius as possible. Common practice is to fabricate the trap using three 90 degree ells.
2. Pressure relief valves are recommended at the condenser for protection of the coil.
3. A pressure valve at the high point in the discharge line is recommended to aid in removing non-condensables.
4. The placement of a subcooler should be that it does not interfere with normal airflow of the condenser. Increased static of the unit could cause a decrease in system capacity and fan motor damage.

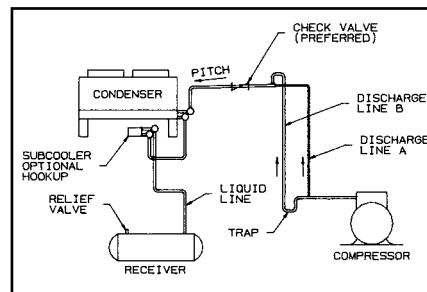


Diagram 2

## City & Tower Water Connections

In the refrigeration industry "City" and "Tower" are designations of temperature and flow conditions, not applications. The term "City" refers to operating conditions where incoming water is 75°F, and condensing temperature is 105°F. "Tower" refers to a higher temperature relationship which is normally 85°F, incoming water and 105°F condensing temperature. Water circuits in some condenser models provide a center, or Tower, outlet connection to allow divided inlet water flow. This extra water port reduces water velocity, water pressure drop, and condenser wear in applications such as cooling towers where higher inlet temperatures and water flows occur.

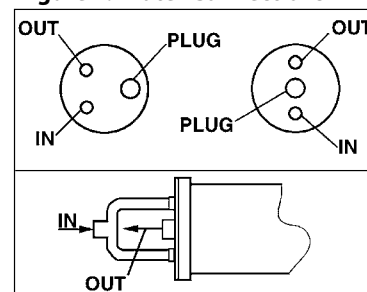
### Water Connections for City

For City water (open system) high pressure applications, the Tower connections is plugged.

### Water Connections for Tower

For Tower usage and low pressure applications, both normal water connections will be used as inlets and the tower connection as an outlet.

Figure 2. Water Connections



### Condensing Unit Rigging and Mounting

Rigging holes are provided on all units. Caution should be exercised when moving these units. To prevent damage to the unit housing during rigging, cables or chains used must be held apart by spacer bars. The mounting platform or base should be level and located so as to permit free access of supply air.

### Ground Mounting

Concrete slab raised six inches above ground level provides a suitable base. Raising the base above ground level provides some protection from ground water and wind blown matter. Before tightening mounting bolts, recheck level of unit. The unit should in all cases be located with a clear space in all directions that is at a minimum, equal to the height of the unit above the mounting surface. A condensing unit mounted in a corner formed by two walls, may result in discharge air recirculation with resulting loss of capacity.

### Roof Mounting

Due to the weight of the units, a structural analysis by a qualified engineer may be required before mounting. Roof mounted units should be installed level on steel channels or an I-beam frame capable of supporting the weight of the unit. Vibration absorbing pads or springs should be installed between the condensing unit legs or frame and the roof mounting assembly.

### Access

Provide adequate space at the compressor end of the unit for servicing. Provide adequate space on the connection side to permit service of components.

### Spring Mounted Compressor

Compressors are secured rigidly to make sure there is no transit damage. Before operating the unit, it is necessary to follow these steps:

- a) Remove the upper nuts and washers.
- b) Discard the shipping spacers.
- c) Install the neoprene spacers. (Spacers located in the electrical panel or tied to compressor.)
- d) Replace the upper mounting nuts and washers.
- e) Allow 1/16 inch space between the mounting nut/washer and rubber spacer. Mounting spring must not be fully compressed when mounting nut is properly installed. See Figures 3 and 5.

### Rigid Mounted Compressor

Some products use rigid mounted compressors. Check the compressor mounting bolts to insure they have not vibrated loose during shipment. See Figure 4.

Figure 3. Spring Mount

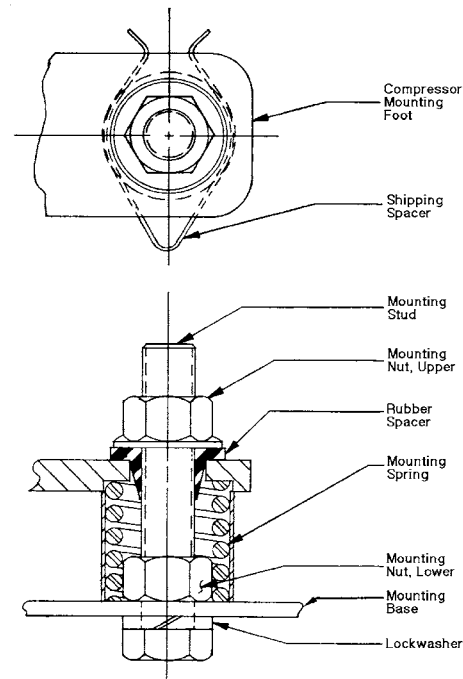


Figure 4. Solid Mount for Mobile or Deep Sump Application

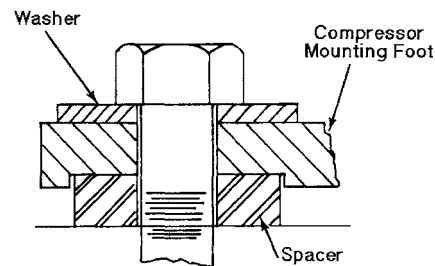
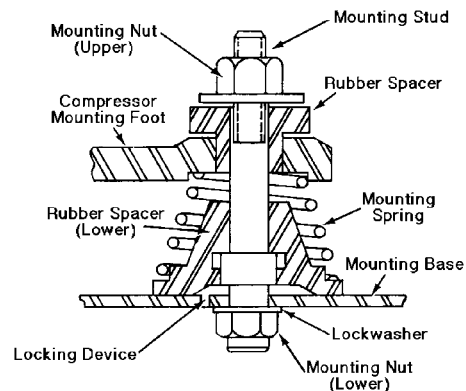


Figure 5. Spring Mount



Mount is shown in properly adjusted position.

## Head Pressure Control

Several types of head pressure control systems are available on condensing units:

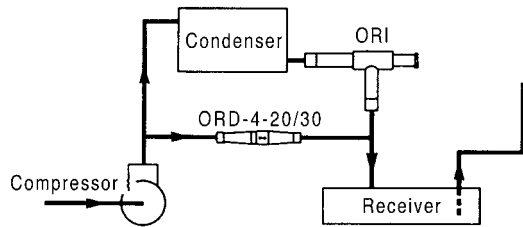
- Dual Valve System. (See section on operation and adjustment.)
- Single Valve system. No adjustments are necessary. (See section on operation.)
- Ambient Fan Cycle Control. (See section on operation and adjustment.)

### A. Dual Valve System

The system employs an ORI (open on rise of inlet pressure) valve and an ORD (open on rise of differential pressure) valve. The high pressure discharge gas is introduced above the liquid in the receiver tank. The receiver discharge is regulated by the ORI valve.

The discharge pressure of the ORI valve must be adjusted to regulate the unit for proper operating conditions. Adjust the ORI valve shown on the following diagram to maintain a discharge pressure of 160 to 180 PSIG.

**Figure 6. Dual Valve Piping Arrangement**

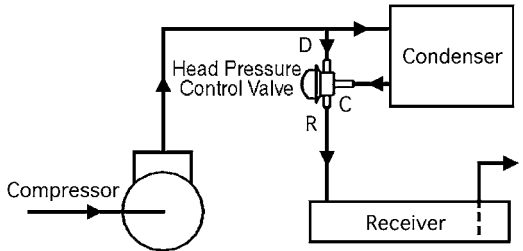


### B. Single Valve System

The standard valve used on high pressure refrigerant systems controls the head pressure at approximately 180 PSIG. There is no adjustment for this valve. On low pressure refrigerant systems the valve controls pressure at approximately 100 PSIG. For energy efficiency, the 100 PSIG valve is sometimes used on high pressure refrigerant systems.

At condensing pressures above the valve setting, flow enters Port C and leaves Port R. When the condensing pressure falls below the valve setting, the valve modulates to permit discharge gas to enter Port D. Metering discharge gas into the refrigerant flow leaving the condenser produces a higher pressure at the condenser outlet, reduces the flow, and causes the level of liquid refrigerant to rise in the condenser. This "flooding" of the condenser with liquid refrigerant reduces the available condensing surface, holding the condensing pressure at the valve setting.

**Figure 7. Single Valve Flooding Valve Piping Arrangement**



## C. Ambient Fan Cycle Control

This is an automatic winter control method which will maintain a condensing pressure within reasonable limits by cycling fan motors in response to outside air temperature. The thermostat(s) should be field adjusted to shut off the fan when the condensing temperature is reduced to approximately 90°F. Table 1 lists approximate settings for several system T.D.'s. These settings are approximate as they do not take into account variations in load.

**Table 1. Ambient Fan Cycle Thermostat Settings**

Models	Design	Thermostat Settings		
	T.D.	T1	T2	T3
2-fan units:	30	60		
	25	65		
4-fan units:	20	70		
	15	75		
3-fan units:	30	60	40	
	25	65	55	
	20	70	60	
6-fan units:	15	75	65	
	30	60	50	30
8-fan units:	25	65	55	40
	20	70	65	50
	15	75	70	60
	30	60	50	30

NOTE: Cycle pairs of fans on double wide units.

### Operation and Adjustment

Condensing units with dual valves require sufficient charge to partially flood the condenser during low ambient conditions.

Valve adjustment should be made with gauges connected to the discharge port of the compressor. Adjustments should be made during mild or low ambient conditions. Turning the valve stem "clockwise" on the ORI valve will increase the discharge pressure, while turning the valve stem "counterclockwise" will decrease the discharge pressure.

If adjustments are made during warm ambient conditions, it may not be possible to adjust the regulator valve as low as desired. Readjustment may be necessary once cooler conditions prevail.

### CAUTION:

Fans closest to the headers should not be cycled on standard temperature or pressure controls. Dramatic temperature and pressure changes at the headers as a result of fan action can result in possible tube failure. Fan motors are designed for continuous duty operation. Fan cycling controls should be adjusted to maintain a minimum of (5) minutes on and (5) minutes off. Short cycling of fans may result in a premature failure of motor and/or fan blade. Compressors operating below +10°F SST must have air flowing over the compressor at all times when the compressor is running.

### CAUTION:

Under no circumstance should all condenser motors be allowed to cycle off on one control. At least one motor shall be wired to operate at all times. Under most circumstances, the condenser motor nearest the inlet header should remain on whenever the compressor is operating.

## Refrigeration Oils\*

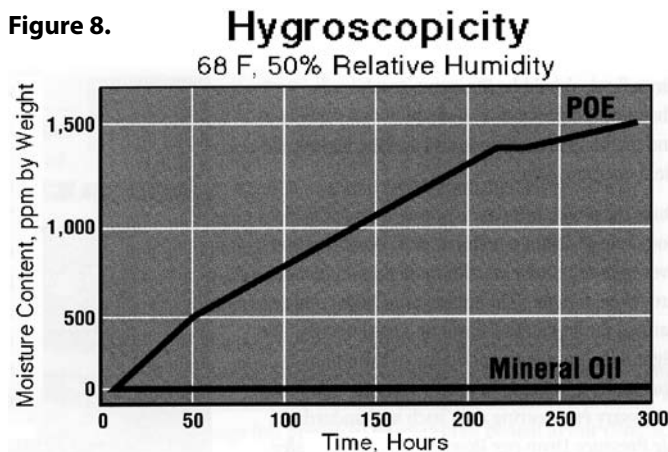
With the changes that have taken place in our industry due to the CFC issue, we have reevaluated our lubricants to ensure compatibility with the new HFC refrigerants and HCFC interim blends offered by several chemical producers. As a secondary criteria, it is also desirable that any new lubricant be compatible with the traditional refrigerants such as HCFC-22 or R502. This "backward compatibility" has been achieved with the introduction of the Polyol ester lubricants.

### Polyol Ester Lubricants

#### Hygroscopicity

Ester lubricants (POE) have the characteristic of quickly absorbing moisture from the ambient surroundings. This is shown graphically in Figure 8 where it can be seen that such lubricants absorb moisture faster and in greater quantity than conventional mineral oils. Since moisture levels greater than 100 ppm will result in system corrosion and ultimate failure, it is imperative that compressors, components, containers and the entire system be kept sealed as much as possible. Lubricants will be packaged in specially designed, sealed containers. After opening, all the lubricant in a container should be used at once since it will readily absorb moisture if left exposed to the ambient. Any unused lubricant should be properly disposed of. Similarly, work on systems and compressors must be carried out with the open time as short as possible. Leaving the system or compressor open during breaks or overnight **MUST BE AVOIDED!**

Figure 8.



#### Color

As received, the POE lubricant will be clear or straw colored. After use, it may acquire a darker color. This does not indicate a problem as the darker color merely reflects the activity of the lubricant's protective additive.

#### Oil Level

During Copeland's testing of Polyol ester oil, it was found that this lubricant exhibits a greater tendency to introduce oil into the cylinder during flooded start conditions. If allowed to continue, this condition will cause mechanical failure of the compressor.

A crankcase heater is required with condensing units and it must be turned on several hours before start-up.

Oil level must not exceed 1/4 sight glass.

## Oil Types

Table 2 below summarizes which oils/lubricants are approved for use in Copeland compressors.

### Mineral Oils

The BR and Scroll compressors use Sontex 200, a "white oil". This oil is not suitable for low temperature applications nor is it available through the normal refrigeration wholesalers. For field "top-off" the use of 3GS or equivalent, or Zerol 200TD is permissible, as long as at least 50% of the total oil charge remains Sontex 200.

Suniso 3GS, Texaco WF32 and Calumet R015 (yellow oils) are available through normal refrigeration wholesalers. These oils are compatible if mixed and can be used on both high and low temperature systems.

### Polyol Ester Lubricants

The Mobil EAL ARCTIC 22 CC is the preferred Polyol ester due to unique additives included in this lubricant. ICI Emkarate RL 32S is an acceptable Polyol ester lubricant approved for use when Mobil is not available. These POE's **must** be used if HFC refrigerants are used in the system. They are also acceptable for use with any of the traditional refrigerants or interim blends and are compatible with mineral oils. They can therefore be mixed with mineral oils when used in systems with CFC or HCFC refrigerants when Copeland compressors are used. These lubricants are compatible with one another and can be mixed.

### Alkyl Benzenes

Zerol 200TD is an alkyl benzene (AB) lubricant. Copeland recommends this lubricant for use as a mixture with mineral oil (MO) when using the interim blends such as R-401A, R-401B and R-402A (MP39, MP66 and HP80). A minimum of 50% AB is required in these mixtures to assure proper oil return. Shell MS 2212 is a 70/30 mixture of AB/MO. If this lubricant is used in a retrofit situation virtually all of the existing MO must be drained prior to refilling with the MS 2212 to assure a minimum 50% AB content.

Table 2. Refrigeration Oils

Refrigeration Oils		Traditional Refrigerants HCFC-22	Interims R401A, R401B, R402A (MP-39, MP-66, HP-80)	HFC's HFC-134a, R404A, R507
POE's	Mobil EAL ARCTIC 22 CC	A	A	P
	ICI (Virginia KMP) EMKARATE RL 32CF	A	A	P
Mineral Oils	Suniso 3GS	P	PM	NOT ACCEPTABLE
	Texaco WF32	P	PM	
	Calumet R015 (Witco)	P	PM	
	Sontex 200-LT (White Oil)	(BR & Scroll Only)		
	Witco LP-200	P		
A/B	Zerol 200TD	AM	PM	NOT ACCEPTABLE
	Soltex Type AB-200		PM	

P = Preferred Lubricant Choice A = Acceptable Alternative M = Mixture of Mineral Oil and Alkyl Benzene (AB) with minimum 50% AB.

\*(Reprinted by permission from Copeland Corporation)

## Phase Loss Monitor

The combination phase sequence and loss monitor relay protects the system against phase loss (single phasing), phase reversal (improper sequence) and low voltage (brownout). When phase sequence is correct and full line voltage is present on all three phases, the relay is energized as the normal condition indicator light glows.

**Note:** If compressor fails to operate and the normal condition indicator light on the phase monitor does not glow, then the supplied electrical current is not in phase with the monitor. This problem is easily corrected by the following steps:

1. Turn power off at disconnect switch.
2. Swap any two of the three power input wires.
3. Turn power on. Indicator light should glow and compressor should start.
4. Observe motors for correct rotation.

## Recommended Refrigerant Piping Practices

The system as supplied by **Heatcraft Refrigeration Products**, was thoroughly cleaned and dehydrated at the factory. Foreign matter may enter the system by way of the evaporator to condensing unit piping. Therefore, care must be used during installation of the piping to prevent entrance of foreign matter.

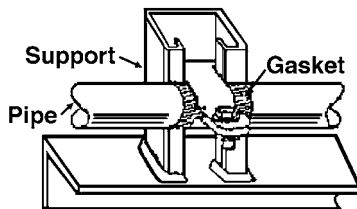
Install all refrigeration system components in accordance with applicable local and national codes and in conformance with good practice required for the proper operation of the system.

The refrigerant pipe size should be selected from the Line Sizing Tables. The interconnecting pipe size is not necessarily the same size as the stub-out on the condensing unit or the evaporator.

The following procedures should be followed:

- a) Do not leave dehydrated compressors or filter-driers on condensing units open to the atmosphere any longer than is absolutely necessary.
- b) Use only refrigeration grade copper tubing, properly sealed against contamination.
- c) Suction lines should slope 1/4" per 10 feet towards the compressor.

**Figure 9. Example of Pipe Support**



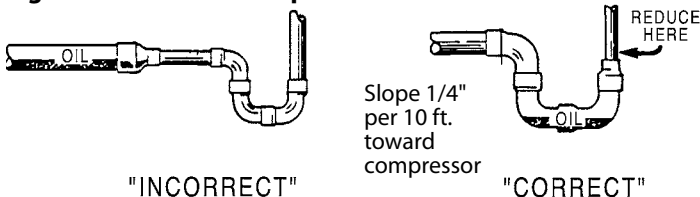
## Suction Lines

Horizontal suction lines should slope away from the evaporator toward the compressor at the rate of 1/4 inch per 10 feet for good oil return. When multiple evaporators are connected in series using a common suction line, the branch suction lines must enter the top of the common suction line.

For dual or multiple evaporator systems, the branch lines to each evaporator should be sized for the evaporator capacity. The main common line should be sized for the total system capacity.

Suction lines that are outside of refrigerated space must be insulated. See the **Line Insulation** section on page 14 for more information.

**Figure 11. Suction P-Traps**



## NOTE:

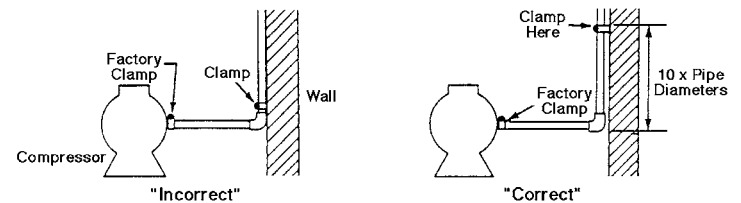
A suction line trap must be installed at the point where piping changes the direction of refrigerant flow from any horizontal run to an upward vertical run.

- d) Suitable P-type oil traps should be located at the base of each suction riser to enhance oil return to the compressor.
- e) For desired method of superheat measurement, a pressure tap should be installed in each evaporator suction line in the proximity of the expansion valve bulb.
- f) **When brazing refrigerant lines, an inert gas should be passed through the line at low pressure to prevent scaling and oxidation inside the tubing. Dry nitrogen is preferred.**
- g) Use only a suitable silver solder alloy on suction and liquid lines.
- h) Limit the soldering paste or flux to the minimum required to prevent contamination of the solder joint internally. Flux only the male portion of the connection, never the female. After brazing, remove excess flux.
- i) See Table 6 for discharge and liquid drain line sizes for remote condenser connections.
- j) If isolation valves are installed at the evaporator, full port ball valves should be used.

## Refrigerant Pipe Support

1. Normally, any straight run of tubing must be supported in at least two locations near each end of the run. Long runs require additional supports. The refrigerant lines should be supported and fastened properly. As a guide, 3/8 to 7/8 should be supported every 5 feet; 1-1/8 and 1-3/8 every 7 feet; and 1-5/8 and 2-1/8 every 9 to 10 feet.
2. When changing directions in a run of tubing, no corner should be left unsupported. Supports should be placed a maximum of 2 feet in each direction from the corner.
3. Piping attached to a vibrating object (such as a compressor or compressor base) must be supported in such a manner that will not restrict the movement of the vibrating object. Rigid mounting will fatigue the copper tubing.
4. Do not use short radius ells. Short radius elbows have points of excessive stress concentration and are subject to breakage at these points.
5. Thoroughly inspect all piping after the equipment is in operation and add supports wherever line vibration is significantly greater than most of the other piping. Extra supports are relatively inexpensive as compared to refrigerant loss.

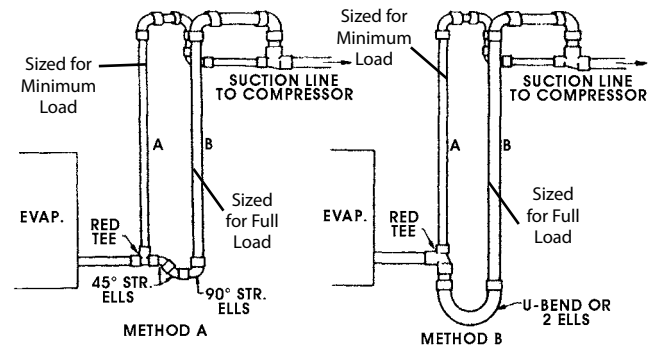
**Figure 10. Condensing Unit / Compressor to Wall Support**



## Suction Line Risers

Prefabricated wrought copper traps are available, or a trap can be made by using two street ells and one regular ell. The suction trap must be the same size as the suction line. For long vertical risers, additional traps may be necessary. Generally, one trap is recommended for each length of pipe (approximately 20 feet) to insure proper oil movement. See Figure 11 for methods of constructing proper suction line P-traps.

**Figure 12. Double Suction Riser Construction**





## Liquid Lines

Liquid lines should be sized for a minimum pressure drop to prevent "flashing". Flashing in the liquid lines would create additional pressure drop and poor expansion valve operation. If a system requires long liquid lines from the receiver to the evaporator or if the liquid has to rise vertically upward any distance, the losses should be calculated to determine whether or not a heat exchanger is required. The use of a suction to liquid heat exchanger may be used to subcool the liquid to prevent flashing. This method of subcooling will normally provide no more than 20°F subcooling on high pressure systems. The amount of subcooling will depend on the design and size of the heat exchanger and on the operating suction and discharge pressures. An additional benefit from the use of the suction to liquid type heat exchanger is that it can help raise the superheat in the suction line to prevent liquid return to the compressor via the suction line. Generally, heat exchangers are not recommended on R-22 low temperature systems. However, they have proved necessary on short, well insulated suction line runs to provide superheat at the compressor.

## Hot Gas Defrost Systems

Hot Gas Defrost systems can be described as reverse cycle, re-evap., or alternating evaporator. Please see manual **H-IM-HGD** for Mohave™ systems.

## Refrigerant Piping

Install all refrigerant components in accordance with applicable local and national codes and in accordance with good practice for proper system operation. The thermostatic expansion valve must be the externally equalized type. It can be mounted inside the unit end compartment. Mount the expansion valve bulb on a horizontal run of suction line as close as possible to the suction header. Use the clamps provided with the valve to fasten the bulb securely so there is a tight line-to-line contact between the bulb and the suction line. Suction and hot gas connections are made on the outside of the unit.

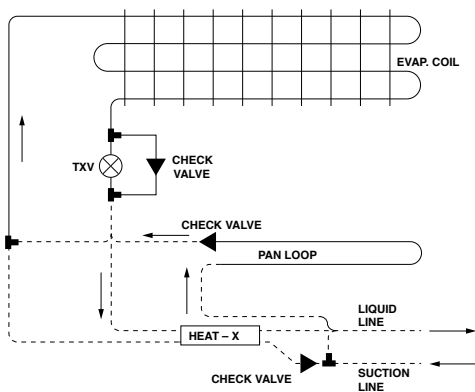
Suction lines should be sloped towards the compressor at the rate of one (1) inch per ten (10) feet for good oil return. Vertical risers of more than four (4) feet should be trapped at the bottom with a P-trap. If a P-trap is used, the expansion valve bulb should be installed between the unit and the trap.

## Reverse Cycle System

The hot gas unit coolers can be used in reverse cycle hot gas defrost systems using multiple evaporators connected to one condensing unit. Generally, not more than one-third of the system defrosts at one time. During the reverse cycle defrost, the reversing valve, located in the compressor discharge line, diverts hot gas through the suction line to the evaporator.

See the piping view in the Reverse Cycle Defrost Piping diagram. The suction line check valve directs the hot gas through the drain pan loop which prevents condensate in the pan from freezing. The hot gas exits the loop at the pan loop outlet header and enters the evaporator through the check valve assembly. As the hot gas defrosts the coil, heat is removed from the hot gas and eventually it condenses into a liquid and exits the coil at the distributor side port. The liquid then flows through the check valve of the thermostatic expansion valve bypass assembly, around the thermostatic expansion valve, and into the system liquid line. The liquid refrigerant then feeds other evaporators on the cooling cycle, evaporates, and returns to the compressor through their suction lines.

## REVERSE CYCLE DEFROST PIPING



## Three Pipe System

The three pipe system (sometimes called re-evap.) uses three pipes: one for liquid line, one for suction line, and one for hot gas line. In addition, a re-evaporator accumulator is used at the suction outlet of the evaporator. The hot gas is taken from the discharge line between the compressor and the condenser, through a hot gas solenoid valve, then to the evaporator drain pan circuit, distributor tee, through the coil. See the **Three-Pipe Defrost Piping Diagram** for typical piping at the evaporator coil.

## Alternating Evaporator System

In the alternating evaporator hot gas defrost system, a third line is taken off the compressor discharge line as the re-evap system. It is piped with solenoids at each evaporator, so that hot gas defrost is accomplished on one or more evaporators while the remaining evaporators continue to function in a normal manner. The liquid from defrosting evaporators is reintroduced to the main liquid line and it is necessary that 75% or greater capacity be retained in the normal refrigeration cycle to offset the capacity that is being removed by the units on the hot gas defrost.

### IMPORTANT:

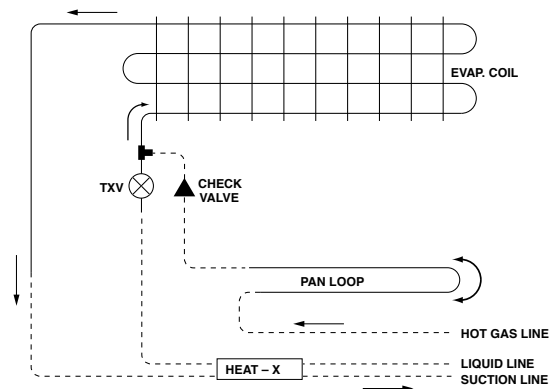
It is imperative that with the alternating evaporator hot gas defrost system, no more than 25% of the operating refrigeration load be in defrost at any time.

## Hot gas line sizes for R-22, R404A and R507

System Capacity BTU/Hr	Equivalent Discharge Length (Ft.)				
	25	50	75	100	150
4,000	1/2	1/2	1/2	1/2	1/2
5,000	1/2	1/2	1/2	1/2	1/2
6,000	1/2	1/2	1/2	5/8	5/8
7,000	1/2	1/2	5/8	5/8	5/8
8,000	1/2	5/8	5/8	5/8	5/8
9,000	1/2	5/8	5/8	5/8	5/8
10,000	1/2	5/8	5/8	5/8	5/8
12,000	5/8	5/8	5/8	7/8	7/8
14,000	5/8	5/8	7/8	7/8	7/8
16,000	5/8	5/8	7/8	7/8	7/8
18,000	5/8	7/8	7/8	7/8	7/8
20,000	5/8	7/8	7/8	7/8	7/8
25,000	7/8	7/8	7/8	7/8	1-1/8
30,000	7/8	7/8	7/8	1-1/8	1-1/8
35,000	7/8	7/8	1-1/8	1-1/8	1-1/8
40,000	7/8	1-1/8	1-1/8	1-1/8	1-1/8
45,000	7/8	1-1/8	1-1/8	1-1/8	1-1/8
50,000	7/8	1-1/8	1-1/8	1-1/8	1-1/8
60,000	1-1/8	1-1/8	1-1/8	1-3/8	1-3/8
70,000	1-1/8	1-1/8	1-3/8	1-3/8	1-3/8
80,000	1-1/8	1-1/8	1-3/8	1-3/8	1-5/8
90,000	1-1/8	1-3/8	1-3/8	1-5/8	1-5/8
100,000	1-1/8	1-3/8	1-3/8	1-5/8	1-5/8

Note: Use next larger hot gas line size for -20°F. and lower suction temperatures.

## THREE-PIPE DEFROST PIPING



## Unit Cooler Piping

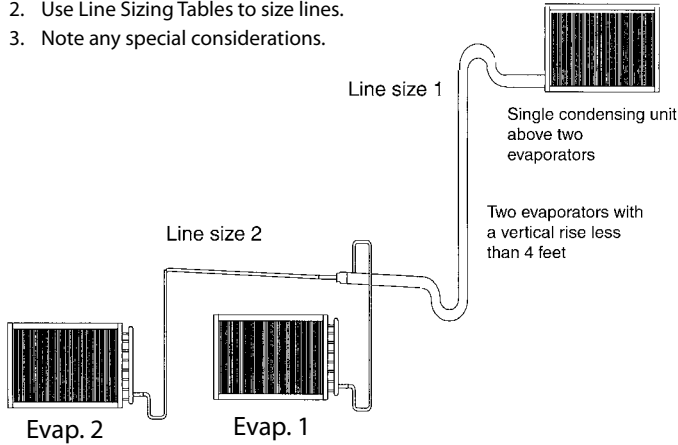
### Pipe size example:

Given: **-10°F Freezer** with one system having (2) evaporators

- One condensing unit rated at 24,000 BTUH's @ -20°F SST R404A refrigerant.
- Two evaporators each rated at 12,000 BTUH's @ 10°F TD.
- 100 feet of actual line run between condensing unit to first evaporator and 20 feet of actual line run between the first evaporator and the second evaporator (see figure below).

### How to figure line sizes:

1. Determine equivalent line run = actual run + valves and fitting allowances.
2. Use Line Sizing Tables to size lines.
3. Note any special considerations.



### Fittings in this system:

- (6) 90° elbows in main line plus a 90° turn through a tee.
- (5) additional 90° elbows to first evaporator.
- (4) additional 90° elbows to second evaporator.

### Determine line size 1 (main line from condensing unit):

1. Main line from the condensing unit to be sized for the total capacity (balance) of the whole system of 24,000 BTUH's (Table 8).
2. Refer to 24,000 @100 feet at -20°F SST R404A on the chart. You will find the suction line to be 1-3/8" and 1/2" liquid line.
3. Refer to Table 5. For every 1-3/8" 90° elbow you must add 4 equivalent feet of pipe and 2.5 equivalent feet of pipe for each 1-3/8" tee.
 

Therefore, total equivalent line run =	
Actual line run	100 feet
+ (6) 1-3/8" elbows @ 4'	24 feet
+ (1) 1-3/8" tee @ 2.5'	2.5 feet
<b>Total equivalent line run</b>	<b>126.5 feet</b>
4. Refer to Table 8. For 126.5 total equivalent feet, the suction line size should be 1-3/8" and the liquid line stays at 1/2" line.

**Note:** The gray shaded areas on Table 8. For 24,000 BTUH's, the maximum suction riser is 1-1/8" to insure proper oil return and pressure drop from the bottom p-trap to the top p-trap.

### Determine line size 2 (evaporators):

1. Line sizing to each evaporator is based on 12,000 BTUH's and equivalent run from condensing unit. First evaporator has an 105 ft. run and the second evaporator has a 120 ft. run.
2. Table 8 indicates 1-1/8" suction for the first evaporator and indicates 1-1/8" suction for the second evaporator.
3. Refer to Table 5. Each 1-1/8" 90° elbow adds 3 equivalent feet of pipe. Each 90° turn through a 1-1/8" tee adds 6 equivalent feet.
 

Actual line run (evap 1)	105 feet
+ (5) 1-1/8" elbows @ 3'	15 feet
+ (1) 90° turn through tee @ 6'	6 feet
<b>Total equivalent line run</b>	<b>126 feet</b>
4.
 

Actual line run (evap 2)	120 feet
+ (4) 1-1/8" elbows @ 3'	12 feet
<b>Total equivalent line run</b>	<b>132 feet</b>
5. Table 8 indicates 1-1/8" suction line and 3/8" liquid line from main line to both evaporators.

## Line Sizing

The following Tables 7 and 8 indicate liquid lines and suction lines for all condensing units for R22, R404A, and R507.

When determining the refrigerant line length, be sure to add an allowance for fittings. See Table 5. Total equivalent length of refrigerant lines is the sum of the actual linear footage and the allowance for fittings.

**Table 3. Weight of Refrigerants in Copper Lines During Operation (Pounds per 100 lineal feet of type "L" tubing)**

Line Size O.D. (Inches)	Refrigerant	Liquid Line	Hot Gas Line	Suction Line at Suction Temperature				
				-40°F	-20°F	0°F	+20°F	+40°F
3/8	22	3.9	0.22	0.02	0.03	0.04	0.06	0.08
	R507, 404A	3.4	0.31	0.03	0.04	0.06	0.09	0.13
1/2	22	7.4	0.41	0.03	0.05	0.07	0.11	0.15
	R507, 404A	6.4	0.58	0.04	0.07	0.13	0.16	0.24
5/8	22	11.8	0.65	0.05	0.08	0.12	0.17	0.25
	R507, 404A	10.3	0.93	0.07	0.11	0.17	0.25	0.35
7/8	22	24.4	1.35	0.10	0.16	0.24	0.36	0.51
	R507, 404A	21.2	1.92	0.15	0.23	0.37	0.51	0.72
1-1/8	22	41.6	2.30	0.17	0.28	0.42	0.61	0.87
	R507, 404A	36.1	3.27	0.26	0.39	0.63	0.86	1.24
1-3/8	22	63.5	3.50	0.27	0.42	0.64	0.93	1.33
	R507, 404A	55.0	4.98	0.40	0.58	0.95	1.32	1.87
1-5/8	22	90.0	4.96	0.37	0.59	0.90	1.33	1.88
	R507, 404A	78.0	7.07	0.56	0.82	1.35	1.86	2.64
2-1/8	22	156	8.61	0.65	1.03	1.57	2.30	3.26
	R507, 404A	134	12.25	0.98	1.43	2.35	3.23	4.58
2-5/8	22	241	13.70	1.01	1.59	2.42	3.54	5.03
	R507, 404A	209	18.92	1.51	2.21	3.62	5.00	7.07
3-1/8	22	344	18.95	1.44	2.28	3.45	5.05	7.18
	R507, 404A	298	27.05	2.16	3.15	5.17	7.14	9.95
3-5/8	22	465	25.60	1.94	3.08	4.67	6.83	9.74
	R507, 404A	403	36.50	2.92	4.25	6.97	19.65	13.67
4-1/8	22	605	33.40	2.53	4.01	6.08	8.90	12.70
	R507, 404A	526	47.57	3.80	5.55	9.09	12.58	17.80

**Table 4. Pressure Loss of Liquid Refrigerants in Liquid Line Risers (Expressed in Pressure Drop, PSIG, and Subcooling Loss, °F)**

Refrigerant	Liquid Line Rise in Feet																	
	10'		15'		20'		25'		30'		40'		50'		75'		100'	
	PSIG	°F	PSIG	°F	PSIG	°F	PSIG	°F	PSIG	°F	PSIG	°F	PSIG	°F	PSIG	°F	PSIG	°F
R22	4.8	1.6	7.3	2.3	9.7	3.1	12.1	3.8	14.5	4.7	19.4	6.2	24.2	8.0	36.3	12.1	48.4	16.5
R507, R404A	4.1	1.1	6.1	1.6	8.2	2.1	10.2	2.7	12.2	3.3	16.3	4.1	20.4	5.6	30.6	8.3	40.8	11.8

Based on 110°F liquid temperature at bottom of riser.

**Table 5. Equivalent Feet of Pipe Due to Valve and Fitting Friction**

Copper Tube, O.D., Type "L"	1/2	5/8	7/8	1-1/8	1-3/8	1-5/8	2-1/8	2-5/8	3-1/8	3-5/8	4-1/8	5-1/8	6-1/8
Globe Valve (Open)	14	16	22	28	36	42	57	69	83	99	118	138	168
Angle Valve (Open)	7	9	12	15	18	21	28	34	42	49	57	70	83
90° Turn Through Tee	3	4	5	6	8	9	12	14	17	20	22	28	34
Tee (Straight Through) or Sweep Below	.75	1	1.5	2	2.5	3	3.5	4	5	6	7	9	11
90° Elbow or Reducing Tee (Straight Through)	1	2	2	3	4	4	5	7	8	10	12	14	16

**Table 6. Recommended Remote Condenser Line Sizes**

Net Evaporator Capacity	Total Equiv. Length	R-22		R507 & R-404A	
		Discharge Line (O.D.)	Liquid Line Cond. to Receiver (O.D.)	Discharge Line (O.D.)	Liquid Line Cond. to Receiver (O.D.)
3,000	50	3/8	3/8	3/8	3/8
	100	3/8	3/8	3/8	3/8
6,000	50	3/8	3/8	1/2	3/8
	100	1/2	3/8	1/2	3/8
9,000	50	1/2	3/8	1/2	3/8
	100	1/2	3/8	1/2	3/8
12,000	50	1/2	3/8	1/2	3/8
	100	5/8	3/8	5/8	1/2
18,000	50	5/8	3/8	5/8	1/2
	100	5/8	3/8	7/8	1/2
24,000	50	5/8	3/8	5/8	1/2
	100	7/8	1/2	7/8	5/8
36,000	50	7/8	1/2	7/8	5/8
	100	7/8	5/8	7/8	7/8
48,000	50	7/8	5/8	7/8	5/8
	100	7/8	7/8	1-1/8	7/8
60,000	50	7/8	5/8	7/8	7/8
	100	1-1/8	7/8	1-1/8	7/8
72,000	50	7/8	7/8	1-1/8	7/8
	100	1-1/8	7/8	1-1/8	1-1/8
90,000	50	1-1/8	7/8	1-1/8	7/8
	100	1-1/8	7/8	1-1/8	1-1/8
120,000	50	1-1/8	7/8	1-1/8	1-1/8
	100	1-3/8	1-1/8	1-3/8	1-3/8
180,000	50	1-3/8	1-1/8	1-3/8	1-3/8
	100	1-5/8	1-3/8	1-5/8	1-5/8
240,000	50	1-3/8	1-3/8	1-5/8	1-3/8
	100	1-5/8	1-3/8	2-1/8	1-5/8
300,000	50	1-5/8	1-3/8	1-5/8	1-5/8
	100	2-1/8	1-5/8	2-1/8	2-1/8
360,000	50	1-5/8	1-5/8	2-1/8	1-5/8
	100	2-1/8	2-1/8	2-1/8	2-1/8
480,000	50	2-1/8	1-5/8	2-1/8	2-1/8
	100	2-1/8	2-1/8	2-1/8	2-5/8
600,000	50	2-1/8	2-1/8	2-1/8	2-1/8
	100	2-5/8	2-5/8	2-5/8	2-5/8
720,000	50	2-1/8	2-1/8	2-1/8	2-5/8
	100	2-5/8	2-5/8	2-5/8	3-1/8
840,000	50	2-1/8	2-1/8	2-5/8	2-5/8
	100	2-5/8	2-5/8	2-5/8	3-1/8
960,000	50	2-5/8	2-5/8	2-5/8	2-5/8
	100	2-5/8	3-1/8	3-1/8	3-5/8
1,080,000	50	2-5/8	2-5/8	2-5/8	3-1/8
	100	3-1/8	3-1/8	3-1/8	3-5/8
1,200,000	50	2-5/8	2-5/8	2-5/8	3-1/8
	100	3-1/8	3-1/8	3-5/8	4-1/8
1,440,000	50	2-5/8	3-1/8	3-1/8	3-5/8
	100	3-1/8	3-5/8	3-5/8	4-1/8
1,680,000	50	3-1/8	3-1/8	3-1/8	3-5/8
	100	3-5/8	3-5/8	3-5/8	4-1/8

**Table 7. Recommended Line Sizes for R-22 \***

Capacity BTUH	Suction Line Size																				Liquid Line Size								
	Suction Temperature																				Receiver to Expansion Valve Equivalent Lengths								
	+40°F Equivalent Lengths				+20°F Equivalent Lengths				+10°F Equivalent Lengths				0°F Equivalent Lengths				-10°F Equivalent Lengths								-20°F Equivalent Lengths				
	25'	50'	100'	150'	25'	50'	100'	150'	25'	50'	100'	150'	25'	50'	100'	150'	25'	50'	100'	150'	25'	50'	100'	150'	25'	50'	100'	150'	
1,000	3/8	3/8	3/8	3/8	3/8	3/8	3/8	3/8	3/8	3/8	3/8	3/8	3/8	3/8	3/8	1/2	3/8	3/8	3/8	1/2	3/8	3/8	1/2	1/2	3/8	3/8	3/8	3/8	
3,000	3/8	3/8	1/2	1/2	3/8	1/2	1/2	5/8	3/8	1/2	1/2	5/8	1/2	1/2	5/8	5/8	1/2	1/2	5/8	5/8	1/2	1/2	5/8	5/8	3/8	3/8	3/8	3/8	
4,000	3/8	3/8	1/2	1/2	3/8	1/2	1/2	5/8	1/2	1/2	5/8	5/8	1/2	1/2	5/8	5/8	1/2	1/2	5/8	5/8	1/2	5/8	5/8	7/8	3/8	3/8	3/8	3/8	
6,000	1/2	1/2	5/8	5/8	1/2	1/2	5/8	5/8	1/2	5/8	5/8	7/8	5/8	5/8	5/8	7/8	1/2	5/8	7/8	7/8	5/8	5/8	7/8	7/8	3/8	3/8	3/8	3/8	
9,000	1/2	5/8	5/8	7/8	1/2	5/8	5/8	7/8	5/8	5/8	7/8	7/8	5/8	7/8	7/8	7/8	5/8	7/8	7/8	7/8	5/8	7/8	7/8	1-1/8	3/8	3/8	3/8	3/8	
12,000	5/8	5/8	7/8	7/8	5/8	5/8	7/8	7/8	5/8	7/8	7/8	7/8	5/8	7/8	7/8	7/8	7/8	7/8	7/8	7/8	1-1/8	7/8	7/8	1-1/8	1-1/8	3/8	3/8	3/8	3/8
15,000	5/8	5/8	7/8	7/8	5/8	7/8	7/8	7/8	7/8	7/8	7/8	1-1/8	7/8	7/8	7/8	1-1/8	7/8	7/8	1-1/8	1-1/8	7/8	7/8	1-1/8	1-1/8	3/8	3/8	3/8	3/8	
18,000	5/8	7/8	7/8	7/8	5/8	7/8	7/8	7/8	7/8	7/8	7/8	1-1/8	7/8	7/8	1-1/8	1-1/8	7/8	7/8	1-1/8	1-1/8	7/8	7/8	1-1/8	1-1/8	3/8	3/8	3/8	1/2	
24,000	5/8	7/8	7/8	1-1/8	7/8	7/8	7/8	1-1/8	7/8	7/8	1-1/8	1-1/8	7/8	1-1/8	1-1/8	1-1/8	7/8	1-1/8	1-1/8	1-1/8	7/8	1-1/8	1-1/8	1-1/8	3/8	3/8	1/2	1/2	
30,000	7/8	7/8	1-1/8	1-1/8	7/8	7/8	1-1/8	1-1/8	7/8	1-1/8	1-1/8	1-1/8	7/8	1-1/8	1-1/8	1-1/8	7/8	1-1/8	1-1/8	1-1/8	1-1/8	1-1/8	1-1/8	1-1/8	3/8	3/8	1/2	1/2	
36,000	7/8	1-1/8	1-1/8	1-1/8	7/8	1-1/8	1-1/8	1-1/8	7/8	1-1/8	1-1/8	1-1/8	7/8	1-1/8	1-1/8	1-1/8	7/8	1-1/8	1-1/8	1-1/8	1-1/8	1-1/8	1-1/8	1-1/8	3/8	1/2	1/2	1/2	
42,000	7/8	1-1/8	1-1/8	1-1/8	7/8	1-1/8	1-1/8	1-1/8	7/8	1-1/8	1-1/8	1-1/8	7/8	1-1/8	1-1/8	1-1/8	7/8	1-1/8	1-1/8	1-1/8	1-1/8	1-1/8	1-1/8	1-1/8	3/8	1/2	1/2	1/2	
48,000	7/8	1-1/8	1-1/8	1-1/8	7/8	1-1/8	1-1/8	1-1/8	7/8	1-1/8	1-1/8	1-1/8	7/8	1-1/8	1-1/8	1-1/8	7/8	1-1/8	1-1/8	1-1/8	1-1/8	1-1/8	1-1/8	1-1/8	1/2	1/2	1/2	1/2	
54,000	7/8	1-1/8	1-1/8	1-1/8	7/8	1-1/8	1-1/8	1-1/8	7/8	1-1/8	1-1/8	1-1/8	7/8	1-1/8	1-1/8	1-1/8	7/8	1-1/8	1-1/8	1-1/8	1-1/8	1-1/8	1-1/8	1-1/8	1/2	1/2	1/2	5/8	
60,000	7/8	1-1/8	1-1/8	1-1/8	7/8	1-1/8	1-1/8	1-1/8	7/8	1-1/8	1-1/8	1-1/8	7/8	1-1/8	1-1/8	1-1/8	7/8	1-1/8	1-1/8	1-1/8	1-1/8	1-1/8	1-1/8	1-1/8	1/2	1/2	5/8	5/8	
66,000	7/8	1-1/8	1-1/8	1-1/8	7/8	1-1/8	1-1/8	1-1/8	7/8	1-1/8	1-1/8	1-1/8	7/8	1-1/8	1-1/8	1-1/8	7/8	1-1/8	1-1/8	1-1/8	1-1/8	1-1/8	1-1/8	1-1/8	1/2	1/2	5/8	5/8	
72,000	1-1/8	1-1/8	1-1/8	1-1/8	7/8	1-1/8	1-1/8	1-1/8	7/8	1-1/8	1-1/8	1-1/8	7/8	1-1/8	1-1/8	1-1/8	7/8	1-1/8	1-1/8	1-1/8	1-1/8	1-1/8	1-1/8	1-1/8	1/2	1/2	5/8	5/8	
78,000	1-1/8	1-1/8	1-1/8	1-1/8	7/8	1-1/8	1-1/8	1-1/8	7/8	1-1/8	1-1/8	1-1/8	7/8	1-1/8	1-1/8	1-1/8	7/8	1-1/8	1-1/8	1-1/8	1-1/8	1-1/8	1-1/8	1-1/8	1/2	1/2	5/8	5/8	
84,000	1-1/8	1-1/8	1-1/8	1-1/8	7/8	1-1/8	1-1/8	1-1/8	7/8	1-1/8	1-1/8	1-1/8	7/8	1-1/8	1-1/8	1-1/8	7/8	1-1/8	1-1/8	1-1/8	1-1/8	1-1/8	1-1/8	1-1/8	1/2	5/8	5/8	5/8	
90,000	1-1/8	1-1/8	1-1/8	1-1/8	7/8	1-1/8	1-1/8	1-1/8	7/8	1-1/8	1-1/8	1-1/8	7/8	1-1/8	1-1/8	1-1/8	7/8	1-1/8	1-1/8	1-1/8	1-1/8	1-1/8	1-1/8	1-1/8	1/2	5/8	5/8	7/8	
120,000	1-1/8	1-1/8	1-1/8	1-1/8	7/8	1-1/8	1-1/8	1-1/8	7/8	1-1/8	1-1/8	1-1/8	7/8	1-1/8	1-1/8	1-1/8	7/8	1-1/8	1-1/8	1-1/8	1-1/8	1-1/8	1-1/8	1-1/8	5/8	5/8	7/8	7/8	
150,000	1-3/8	1-1/8	1-1/8	2-1/8	7/8	1-1/8	1-1/8	1-1/8	7/8	1-1/8	1-1/8	1-1/8	7/8	1-1/8	1-1/8	1-1/8	7/8	1-1/8	1-1/8	1-1/8	1-1/8	1-1/8	1-1/8	1-1/8	5/8	7/8	7/8	7/8	
180,000	1-3/8	1-1/8	2-1/8	2-1/8	7/8	1-1/8	1-1/8	1-1/8	7/8	1-1/8	1-1/8	1-1/8	7/8	1-1/8	1-1/8	1-1/8	7/8	1-1/8	1-1/8	1-1/8	1-1/8	1-1/8	1-1/8	1-1/8	5/8	7/8	7/8	7/8	
210,000	1-3/8	1-1/8	2-1/8	2-1/8	7/8	1-1/8	1-1/8	1-1/8	7/8	1-1/8	1-1/8	1-1/8	7/8	1-1/8	1-1/8	1-1/8	7/8	1-1/8	1-1/8	1-1/8	1-1/8	1-1/8	1-1/8	1-1/8	7/8	7/8	7/8	7/8	
240,000	1-5/8	1-1/8	2-1/8	2-1/8	7/8	1-1/8	1-1/8	1-1/8	7/8	1-1/8	1-1/8	1-1/8	7/8	1-1/8	1-1/8	1-1/8	7/8	1-1/8	1-1/8	1-1/8	1-1/8	1-1/8	1-1/8	1-1/8	7/8	7/8	7/8	1-1/8	
300,000	1-5/8	2-1/8	2-1/8	2-1/8	7/8	1-1/8	1-1/8	1-1/8	7/8	1-1/8	1-1/8	1-1/8	7/8	1-1/8	1-1/8	1-1/8	7/8	1-1/8	1-1/8	1-1/8	1-1/8	1-1/8	1-1/8	1-1/8	7/8	7/8	1-1/8	1-1/8	
360,000	2-1/8	2-1/8	2-1/8	2-1/8	7/8	1-1/8	1-1/8	1-1/8	7/8	1-1/8	1-1/8	1-1/8	7/8	1-1/8	1-1/8	1-1/8	7/8	1-1/8	1-1/8	1-1/8	1-1/8	1-1/8	1-1/8	1-1/8	7/8	7/8	1-1/8	1-1/8	
480,000	2-1/8	2-1/8	2-1/8	2-1/8	7/8	1-1/8	1-1/8	1-1/8	7/8	1-1/8	1-1/8	1-1/8	7/8	1-1/8	1-1/8	1-1/8	7/8	1-1/8	1-1/8	1-1/8	1-1/8	1-1/8	1-1/8	1-1/8	1-1/8	1-1/8	1-1/8	1-1/8	
600,000	2-1/8	2-1/8	2-1/8	3-1/8	7/8	1-1/8	1-1/8	1-1/8	7/8	1-1/8	1-1/8	1-1/8	7/8	1-1/8	1-1/8	1-1/8	7/8	1-1/8	1-1/8	1-1/8	1-1/8	1-1/8	1-1/8	1-1/8	1-1/8	1-1/8	1-1/8	1-1/8	

**\* NOTES:**

- Sizes that are highlighted indicate maximum suction line sizes that should be used for risers. Riser size should not exceed horizontal size. Properly placed suction traps must also be used for adequate oil return. All sizes shown are for O.D. Type L copper tubing.
- Suction line sizes selected at pressure drop equivalent to 2°F. Reduce estimate of system capacity accordingly.
- Recommended liquid line size may increase with reverse cycle hot gas systems.
- If system load drops below 40% of design, consideration to installing double suction risers should be made.

**Table 8. Recommended Line Sizes for R-404A and R507\***

Capacity BTUH	Suction Line Size																								Liquid Line Size				
	Suction Temperature																								Receiver to Expansion Valve Equivalent Lengths				
	+20°F Equivalent Lengths				+10°F Equivalent Lengths				-10°F Equivalent Lengths				-20°F Equivalent Lengths				-30°F Equivalent Lengths				-40°F Equivalent Lengths								
	25'	50'	100'	150'	25'	50'	100'	150'	25'	50'	100'	150'	25'	50'	100'	150'	25'	50'	100'	150'	25'	50'	100'	150'	25'	50'	100'	150'	
1,000	3/8	3/8	3/8	3/8	3/8	3/8	3/8	3/8	3/8	3/8	1/2	1/2	3/8	3/8	1/2	1/2	3/8	3/8	1/2	1/2	3/8	1/2	1/2	5/8	3/8	3/8	3/8	3/8	
3,000	3/8	3/8	1/2	1/2	3/8	1/2	1/2	5/8	1/2	1/2	5/8	5/8	1/2	1/2	5/8	7/8	1/2	1/2	5/8	7/8	1/2	1/2	5/8	7/8	3/8	3/8	3/8	3/8	
4,000	3/8	1/2	1/2	5/8	1/2	1/2	5/8	5/8	1/2	5/8	5/8	7/8	1/2	5/8	7/8	7/8	5/8	5/8	7/8	7/8	1/2	5/8	7/8	7/8	3/8	3/8	3/8	3/8	
6,000	1/2	1/2	5/8	7/8	1/2	1/2	5/8	7/8	1/2	5/8	7/8	7/8	5/8	5/8	7/8	7/8	5/8	5/8	7/8	7/8	5/8	5/8	7/8	7/8	3/8	3/8	3/8	3/8	
9,000	5/8	5/8	7/8	7/8	5/8	5/8	7/8	7/8	5/8	7/8	7/8	7/8	5/8	7/8	7/8	1-1/8	5/8	7/8	7/8	1-1/8	5/8	7/8	7/8	1-1/8	3/8	3/8	3/8	3/8	
12,000	5/8	7/8	7/8	7/8	5/8	7/8	7/8	7/8	7/8	7/8	7/8	1-1/8	7/8	7/8	1-1/8	1-1/8	7/8	7/8	1-1/8	1-1/8	7/8	7/8	1-1/8	1-1/8	3/8	3/8	3/8	3/8	
15,000	5/8	7/8	7/8	7/8	7/8	7/8	1-1/8	7/8	7/8	1-1/8	1-1/8	1-1/8	7/8	7/8	1-1/8	1-1/8	7/8	7/8	1-1/8	1-1/8	7/8	7/8	1-1/8	1-1/8	3/8	3/8	3/8	1/2	
18,000	7/8	7/8	7/8	1-1/8	7/8	7/8	1-1/8	1-1/8	7/8	7/8	1-1/8	1-1/8	7/8	1-1/8	1-1/8	3/8	7/8	1-1/8	1-1/8	3/8	7/8	1-1/8	1-1/8	1-1/8	3/8	3/8	1/2	1/2	
24,000	7/8	7/8	1-1/8	1-1/8	7/8	1-1/8	1-1/8	1-1/8	7/8	1-1/8	1-1/8	3/8	1-1/8	1-1/8	1-1/8	3/8	1-1/8	1-1/8	1-1/8	3/8	1-1/8	1-1/8	1-1/8	1-1/8	3/8	3/8	1/2	1/2	
30,000	7/8	7/8	1-1/8	1-1/8	7/8	1-1/8	1-1/8	1-1/8	1-1/8	1-1/8	1-1/8	3/8	1-1/8	1-1/8	1-1/8	3/8	1-1/8	1-1/8	1-1/8	3/8	1-1/8	1-1/8	1-1/8	1-1/8	3/8	1/2	1/2	1/2	
36,000	7/8	1-1/8	1-1/8	1-1/8	1-1/8	1-1/8	1-1/8	1-1/8	1-1/8	1-1/8	1-1/8	3/8	1-1/8	1-1/8	1-1/8	3/8	1-1/8	1-1/8	1-1/8	3/8	1-1/8	1-1/8	1-1/8	1-1/8	3/8	1/2	1/2	1/2	
42,000	1-1/8	1-1/8	1-1/8	1-1/8	1-1/8	1-1/8	1-1/8	1-1/8	1-1/8	1-1/8	1-1/8	3/8	1-1/8	1-1/8	1-1/8	3/8	1-1/8	1-1/8	1-1/8	3/8	1-1/8	1-1/8	1-1/8	1-1/8	1-1/8	1/2	1/2	1/2	5/8
48,000	1-1/8	1-1/8	1-1/8	1-1/8	1-1/8	1-1/8	1-1/8	1-1/8	1-1/8	1-1/8	1-1/8	3/8	1-1/8	1-1/8	1-1/8	3/8	1-1/8	1-1/8	1-1/8	3/8	1-1/8	1-1/8	1-1/8	1-1/8	1-1/8	1/2	1/2	5/8	5/8
54,000	1-1/8	1-1/8	1-1/8	1-1/8	1-1/8	1-1/8	1-1/8	1-1/8	1-1/8	1-1/8	1-1/8	3/8	1-1/8	1-1/8	1-1/8	3/8	1-1/8	1-1/8	1-1/8	3/8	1-1/8	1-1/8	1-1/8	1-1/8	1-1/8	1/2	1/2	5/8	5/8
60,000	1-1/8	1-1/8	1-1/8	1-1/8	1-1/8	1-1/8	1-1/8	1-1/8	1-1/8	1-1/8	1-1/8	3/8	1-1/8	1-1/8	1-1/8	3/8	1-1/8	1-1/8	1-1/8	3/8	1-1/8	1-1/8	1-1/8	1-1/8	1-1/8	1/2	1/2	5/8	5/8
66,000	1-1/8	1-1/8	1-1/8	1-1/8	1-1/8	1-1/8	1-1/8	1-1/8	1-1/8	1-1/8	1-1/8	3/8	1-1/8	1-1/8	1-1/8	3/8	1-1/8	1-1/8	1-1/8	3/8	1-1/8	1-1/8	1-1/8	1-1/8	1-1/8	1/2	1/2	5/8	5/8
72,000	1-1/8	1-1/8	1-1/8	1-1/8	1-1/8	1-1/8	1-1/8	1-1/8	1-1/8	1-1/8	1-1/8	3/8	1-1/8	1-1/8	1-1/8	3/8	1-1/8	1-1/8	1-1/8	3/8	1-1/8	1-1/8	1-1/8	1-1/8	1-1/8	1/2	5/8	5/8	5/8
78,000	1-1/8	1-1/8	1-1/8	1-1/8	1-1/8	1-1/8	1-1/8	1-1/8	1-1/8	1-1/8	1-1/8	3/8	1-1/8	1-1/8	1-1/8	3/8	1-1/8	1-1/8	1-1/8	3/8	1-1/8	1-1/8	1-1/8	1-1/8	1-1/8	5/8	5/8	5/8	5/8
84,000	1-1/8	1-1/8	1-1/8	1-1/8	1-1/8	1-1/8	1-1/8	1-1/8	1-1/8	1-1/8	1-1/8	3/8	1-1/8	1-1/8	1-1/8	3/8	1-1/8	1-1/8	1-1/8	3/8	1-1/8	1-1/8	1-1/8	1-1/8	1-1/8	5/8	5/8	5/8	7/8
90,000	1-3/8	1-3/8	1-3/8	2-1/8	1-3/8	1-3/8	1-3/8	2-1/8	1-3/8	1-3/8	2-1/8	2-1/8	1-3/8	1-3/8	2-1/8	2-1/8	1-3/8	1-3/8	2-1/8	2-1/8	1-3/8	1-3/8	2-1/8	2-1/8	5/8	5/8	7/8	7/8	
120,000	1-3/8	1-3/8	2-1/8	2-1/8	1-3/8	1-3/8	2-1/8	2-1/8	1-3/8	2-1/8	2-1/8	2-1/8	1-3/8	1-3/8	2-1/8	2-1/8	1-3/8	1-3/8	2-1/8	2-1/8	1-3/8	1-3/8	2-1/8	2-1/8	5/8	5/8	7/8	7/8	
150,000	1-5/8	1-5/8	2-1/8	2-1/8	1-5/8	1-5/8	2-1/8	2-1/8	1-5/8	2-1/8	2-1/8	2-1/8	1-5/8	1-5/8	2-1/8	2-1/8	1-5/8	1-5/8	2-1/8	2-1/8	1-5/8	1-5/8	2-1/8	2-1/8	5/8	7/8	7/8	7/8	
180,000	1-5/8	2-1/8	2-1/8	2-1/8	1-5/8	1-5/8	2-1/8	2-1/8	1-5/8	2-1/8	2-1/8	2-1/8	1-5/8	1-5/8	2-1/8	2-1/8	1-5/8	1-5/8	2-1/8	2-1/8	1-5/8	1-5/8	2-1/8	2-1/8	7/8	7/8	7/8	1-1/8	
210,000	1-5/8	2-1/8	2-1/8	2-1/8	2-1/8	2-1/8	2-1/8	2-1/8	2-1/8	2-1/8	2-1/8	3-1/8	2-1/8	2-1/8	2-1/8	3-1/8	2-1/8	2-1/8	2-1/8	3-1/8	2-1/8	2-1/8	2-1/8	2-1/8	7/8	7/8	1-1/8	1-1/8	
240,000	1-5/8	2-1/8	2-1/8	2-1/8	2-1/8	2-1/8	2-1/8	2-1/8	2-1/8	2-1/8	2-1/8	3-1/8	2-1/8	2-1/8	2-1/8	3-1/8	2-1/8	2-1/8	2-1/8	3-1/8	2-1/8	2-1/8	2-1/8	2-1/8	7/8	7/8	1-1/8	1-1/8	
300,000	2-1/8	2-1/8	2-1/8	2-1/8	2-1/8	2-1/8	2-1/8	2-1/8	2-1/8	2-1/8	2-1/8	3-1/8	2-1/8	2-1/8	2-1/8	3-1/8	2-1/8	2-1/8	2-1/8	3-1/8	2-1/8	2-1/8	2-1/8	2-1/8	7/8	1-1/8	1-1/8	1-1/8	
360,000	2-1/8	2-1/8	2-1/8	3-1/8	2-1/8	2-1/8	2-1/8	3-1/8	2-1/8	2-1/8	3-1/8	3-1/8	2-1/8	2-1/8	3-1/8	3-1/8	2-1/8	2-1/8	3-1/8	3-1/8	2-1/8	3-1/8	3-1/8	2-1/8	1-1/8	1-1/8	1-1/8	1-1/8	
480,000	2-1/8	2-1/8	3-1/8	3-1/8	2-1/8	2-1/8	2-1/8	3-1/8	2-1/8	3-1/8	3-1/8	3-1/8	2-1/8	3-1/8	3-1/8	3-1/8	2-1/8	3-1/8	3-1/8	3-1/8	2-1/8	3-1/8	3-1/8	2-1/8	1-1/8	1-1/8	1-1/8	1-1/8	
600,000	2-5/8	2-5/8	3-1/8	3-1/8	2-5/8	2-5/8	3-1/8	3-1/8	2-5/8	3-1/8	3-1/8	4-1/8	2-5/8	3-1/8	3-1/8	3-1/8	2-5/8	3-1/8	3-1/8	3-1/8	2-5/8	3-1/8	3-1/8	2-5/8	1-1/8	1-1/8	1-1/8	1-1/8	

**\* NOTES:**

- Sizes that are highlighted indicate maximum suction line sizes that should be used for risers. Riser size should not exceed horizontal size. Properly placed suction traps must also be used for adequate oil return. All sizes shown are for O.D. Type L copper tubing.
- Suction line sizes selected at pressure drop equivalent to 2°F. Reduce estimate of system capacity accordingly.
- Recommended liquid line size may increase with reverse cycle hot gas systems.
- If system load drops below 40% of design, consideration to installing double suction risers should be made.

## Evacuation and Leak Detection

Due to the smaller molecule size of HFC's, they will tend to leak more readily than CFC's. Consequently, it is of the utmost importance that proper system evacuation and leak detection procedures be employed.

Copeland recommends a minimum evacuation to 500 microns. In addition, a vacuum decay test is strongly recommended to assure there is not a large pressure differential between the system and vacuum pump. Good evacuation processes include frequent vacuum pump oil changes and large diameter, short hose connections to both high and low sides of the system preferably using bronze braided hose.

Leak detection can be carried out in the conventional manner.

If HCFC or CFC tracer gas is used, care must be taken to completely remove all traces of the gas prior to introducing HFC's.

Electronic leak detectors are now available that will sense HFC's. This is considered preferable since it removes the possibility of chlorine remaining in the system after leak testing with HCFC's and/or CFC's. There is a view that even small quantities of chlorine may act as a catalyst encouraging copper plating and/or corrosion and should therefore be avoided.

### WARNING:

HFC-134a has been shown to be combustible at pressure as low as 5.5 psig (at 350°F) when mixed with air at concentrations more than 60% air by volume.

At lower temperature, higher pressures are required to support combustion. Therefore, air should never be mixed with HFC-134a for leak detection.

Within the last several years, manufacturers have developed fluorescent dye leak detection systems for use with refrigerants. These dyes mix with the lubricant and, when exposed to an ultraviolet light "fluoresce," indicates the location of leaks. Copeland has tested and approved the Rigid "System Safe" dye and found it to be compatible with the compressor materials in systems.

### Leak Testing

After all lines are connected, the entire system must be leak tested. The complete system should be pressurized to not more than 150 psig with refrigerant and dry nitrogen (or dry CO<sub>2</sub>). The use of an electronic type leak detector is highly recommended because of its greater sensitivity to small leaks. As a further check it is recommended that this pressure be held for a minimum of 12 hours and then rechecked. For a satisfactory installation, the system must be leak tight.

### Line Insulation

After the final leak test, refrigerant lines exposed to high ambient conditions should be insulated to reduce heat pickup and prevent the formation of flash gas in the liquid lines. Suction lines must always be insulated with 3/4" wall Armstrong "Armaflex" or equal. When required, Liquid lines should be insulated with 1/2 inch wall insulation or better. The insulation located in outdoor environments should be protected from UV exposure to prevent deterioration of insulating value.

### Evacuation

#### CAUTION:

Do not use the refrigeration compressor to evacuate the system. Do not start the compressor while it is in a vacuum.

A good, deep vacuum pump should be connected to both the low and high side evacuation valves with copper tube or high vacuum hoses (1/4" ID minimum). If the compressor has service valves, they should remain closed. A deep vacuum gauge capable of registering pressure in microns should be attached to the system for pressure readings.

A shut off valve between the gauge connection and vacuum pump should be provided to allow the system pressure to be checked after evacuation. Do not turn off vacuum pump when connected to an evacuated system before closing shut off valve.

The vacuum pump should be operated until a pressure of 1,500 microns absolute pressure is reached — at which time the vacuum should be broken with the refrigerant to be used in the system through a drier until the system pressure rises above "0" psig.

#### NOTE:

Refrigerant used during evacuation cannot be vented. Reclaim all used refrigerant. EPA regulations are constantly being updated. Ensure your procedure follows correct regulations.

Repeat this operation a second time.

Open the compressor service valves and evacuate the entire system to 500 microns absolute pressure. Raise the pressure to 2 psig with the refrigerant and remove the vacuum pump.

## Refrigerant Charging Instructions

1. Install a liquid line drier in the refrigerant supply line between the service gauge and the liquid service port of the receiver. This extra drier will insure that all refrigerant supplied to the system is clean and dry.
2. When initially charging a system that is in a vacuum, liquid refrigerant can be added directly into the receiver tank.
3. Check equipment catalog for refrigerant capacity. System refrigerant capacity is 90% of receiver capacity. Do not add more refrigerant than the data tag indicates, unless the line run exceeds 25ft. Then, add additional refrigerant as per the chart on page 30. Weigh the refrigerant drum before charging so an accurate record can be kept of the weight of refrigerant put in the system.
4. Start the system and finish charging until the sight glass indicates a full charge and the proper amount has been weighed in. If the refrigerant must be added to the system through the suction side of the compressor, charge in vapor form only. Liquid charging must be done in the high side only or with liquid metering devices to protect the compressor.

### Low Head Pressure Systems

If you are charging the system by using a clear sight glass as an indication of proper charge the following must be considered.

Check the condensing temperature. It must be above 105°F. If not, it will be necessary to reduce the amount of air going through the condenser from fans still running. Simply reduce the effective condenser face area to raise the discharge pressure above the equivalent 105°F condensing temperature and then proceed to charge to clear the sightglass. Adjust evaporator superheat at this time. Return to full condenser face area and allow the system to balance.

### Field Wiring

#### WARNING:

All wiring must be done in accordance with applicable codes and local ordinances.

The field wiring should enter the areas as provided on the unit. The wiring diagram for each unit is located on the inside of the electrical panel door. All field wiring should be done in a professional manner and in accordance with all governing codes. Before operating unit, double check all wiring connections, including the factory terminals. Factory connections can vibrate loose during shipment.

1. The serial data tag on the unit is marked with the electrical characteristic for wiring the unit.
2. Consult the wiring diagram in the unit cooler and in the condensing unit for proper connections.
3. Wire type should be of copper conductor only and of the proper size to handle the connected load.
4. The unit must be grounded.
5. For multiple evaporator systems, the defrost termination controls should be wired in series. Follow the wiring diagrams for multiple evaporator systems carefully. This will assure complete defrost of all evaporators in the system.
6. Multiple evaporator systems should operate off of one thermostat.
7. If a remote defrost timer is to be used, the timer should be located outside the refrigerated space.
8. For air cooled condensers, due to multiple low amp motors, we recommend using time delay fuse protection instead of circuit breakers.

## Check Out and Start Up

After the installation has been completed, the following points should be covered before the system is placed in operation:

- a) Check all electrical and refrigerant connections. Be sure they are all tight.
- b) Observe compressor oil level before start-up. The oil level should be at or slightly above the 1/4 level of the sight glass. Refer to Table 3 for proper compressor oil.
- c) Remove upper mounting nuts on the compressor feet. Remove the shipping spacers. Install the neoprene washers onto the compressor feet. Replace the upper mounting nuts and washers, allowing 1/16" space between the mounting nut and the neoprene spacer.
- d) Check high and low pressure controls, pressure regulating valves, oil pressure safety controls, and all other safety controls, and adjust if necessary.
- e) Check the room thermostat for normal operation and adjust.
- f) Wiring diagrams, instruction bulletins, etc. attached to the condensing units should be read and filed for future reference.
- g) All fan motors should be checked for proper rotation. Fan motor mounts should be carefully checked for tightness and proper alignment.
- h) Electric and hot gas evaporator fan motors should be temporarily wired for continuous operation until the room temperature has stabilized.
- i) Observe system pressures during charging and initial operation. Do not add oil while the system is short of refrigerant unless oil level is dangerously low.
- j) Continue charging until system has sufficient refrigerant for proper operation. Do not overcharge. Remember that bubbles in a sight glass may be caused by a restriction as well as a shortage of refrigerant.
- k) Do not leave unit unattended until the system has reached normal operating conditions and the oil charge has been properly adjusted to maintain the oil level between 1/4 and bottom of the sight glass.
- l) Make sure all Schrader valve caps are in place and tight.
- m) Make sure ALL service valves are properly back-seated and tighten valve packing if necessary.

### CAUTION:

Extreme care must be taken in starting compressors for the first time after system charging. At this time, all of the oil and most of the refrigerant might be in the compressor creating a condition which could cause compressor damage due to slugging. Activating the crankcase heater for 24 hours prior to start-up is required. If no crankcase heater is present, then directing a 500 watt heat lamp or other safe heat source on the lower shell of the compressor for approximately thirty minutes will be beneficial in eliminating this condition which might never reoccur.

### WARNING:

Scroll compressor is directional dependent. If noisy, change phase of input wiring.

## Operational Check Out

After the system has been charged and has operated for at least two hours at normal operating conditions without any indication of malfunction, it should be allowed to operate overnight on automatic controls. Then a thorough recheck of the entire system operation should be made as follows:

- a) Check compressor discharge and suction pressures. If not within system design limits, determine why and take corrective action.
- b) Check liquid line sight glass and expansion valve operation. If there are indications that more refrigerant is required, leak test all connections and system components and repair any leaks before adding refrigerant.
- c) Observe oil level in compressor crankcase sight glass. Add oil as necessary to bring level to bottom 1/4 of the sight glass.
- d) Thermostatic expansion valves must be checked for proper superheat settings. Feeler bulbs must be in positive contact with the suction line and should be insulated. Valves set at high superheat will lower refrigeration capacity. Low superheat promotes liquid slugging and compressor bearing washout.
- e) Using suitable instruments, carefully check line voltage and amperage at the compressor terminals. Voltage must be within 10% of that indicated on the condensing unit nameplate. If high or low voltage is indicated, notify the power company. If amperage draw is excessive, immediately determine the cause and take corrective action. On three phase motor compressors, check to see that a balanced load is drawn by each phase.
- f) The maximum approved settings for high pressure controls on our air cooled condensing equipment is 425 psig. On air cooled systems, check as follows:  
Disconnect the fan motors or block the condenser inlet air. Watch high pressure gauge for cutout point. Recheck all safety and operating controls for proper operation and adjust if necessary.
- g) Check defrost controls for initiation and termination settings, and length of defrost period. Set fail safe at length of defrost + 25%.  
Example: 20 minute defrost + 5 minutes  
= 25 minute fail safe
- h) Check drain pan for proper drainage.
- i) Check winter head pressure controls for pressure setting.
- j) Check crankcase heater operation if used.
- k) Install instruction card and control system diagram for use of building manager or owner.

## System Balancing - Compressor Superheat

### IMPORTANT:

In order to obtain the maximum capacity from a system, and to ensure trouble-free operation, it is necessary to balance each and every system.

This is extremely important with any refrigeration system.

The critical value which must be checked is suction superheat.

Suction superheat should be checked **at the compressor** as follows:

1. Measure the suction pressure at the suction service valve of the compressor and determine the saturation temperature corresponding to this pressure from a "Temperature-Pressure" chart.
2. Measure the suction temperature of the suction line about one foot back from the compressor using an accurate thermometer.
3. Subtract the saturated temperature from the actual suction line temperature. The difference is superheat.

Too low a suction superheat can result in liquid being returned to the compressor. This will cause dilution of the oil and eventual failure of the bearings and rings or in the extreme case, valve failure.

Too high a suction superheat will result in excessive discharge temperatures which cause a break down of the oil and results in piston ring wear, piston and cylinder wall damage.

It should also be remembered that the system capacity decreases as the suction superheat increases. For maximum system capacity, suction superheat should be kept as low as is practical. Copeland mandates a **minimum** superheat of 20°F **at the compressor**. We recommend that the superheat **at the compressor** be between 20°F and 30°F.

If adjustments to the suction superheat need to be made, the expansion valve at the evaporator should be adjusted.

### NOTE:

All adjustable controls and valves must be field adjusted to meet desired operation. There are no factory preset controls or valve adjustments. This includes low pressure, high pressure, adjustable head pressure systems and expansion valves.

**Table 9. Recommended Low Pressure Control Settings for Outdoor Air Cooled Condensing Units**

*Minimum Temp. °F	R-22		R-404A/R-507	
	Cut-In PSI	Cut-Out PSI	Cut-In PSI	Cut-Out PSI
50	70	20	90	35
40	55	20	70	35
30	40	20	55	35
10	30	10	45	25
0	15	0	25	7
-10	15	0	20	1
-20	10	0	12	1
-30	6	0	8	1"Hg.

\* Minimum ambient or box temperature anticipated, high pressure control setting: R-22, 360 PSI; R-404A, R-507, 400 PSI

\* The standard preset low pressure switch used for pumpdown is set for 15 PSI cut in / 4 PSI cut out and is a good setting for most pumpdown systems

\* ZB Scroll compressors should be set for 25 PSI cut in / 17 PSI cut out (R-404A / R-507)



## General Sequence of Operation

### Refrigeration Cycle

1. Power is supplied to the timer at terminals "1" and "N".
2. The fan delay and the defrost termination thermostat is closed in the fan delay position and open in the defrost termination position. The unit cooler fans run continuously.
3. The defrost heaters are off.
4. The room thermostat closes when the temperature rises above the desired setting.
5. The liquid line solenoid is energized and opens, which allows liquid refrigerant to flow through the unit cooler.
6. The low pressure control closes when the suction pressure rises above the cutin setting of the control.
7. On systems with oil pumps, the oil safety control is closed. If the net oil pressure is less than 9 PSIG for more than 120 seconds, the oil safety opens, thus breaking the circuit to the compressor contactor holding coil. The compressor will not operate. This control is reset manually and must be reset before the compressor can be restarted.
8. The compressor contactor closes. The compressor and condenser fan start simultaneously.
9. The room temperature gradually decreases to the desired temperature.
10. Once the desired temperature is reached, the thermostat opens and the liquid line solenoid closes, stopping refrigerant flow through the evaporator.
11. Suction pressure decreases and the compressor contactor opens when the pressure drops below the cutout setting on the low pressure control. The compressor and condenser fan stop running.
12. This cycle is repeated as many times as necessary to satisfy the room thermostat.
13. Frost starts to form on the evaporator coil and continues to form until the defrost cycle is initiated.

### Defrost Cycle

1. The defrost cycle starts automatically by the timer at predetermined times. Typical settings are two to four defrost cycles per day for freezers. For heavier frost loads additional settings may be required.
2. Switch "2" to "4" opens in the timer which breaks the circuit to the room thermostat, liquid line solenoid, and evaporator fan motors, allowing the compressor to pump down and shut off. Simultaneously switch "1" to "3" closes in the timer allowing current to flow to one side of the defrost heater contactor. When the compressor shuts off, an auxiliary contact will send power to the contactor holding coil; thus, energizing the defrost heaters.
3. The heaters raise the temperature of the coil to 32°F causing the frost to melt off the coil.
4. When the coil warms to 45°F to 55°F, the defrost termination thermostat closes, which allows current to the switching solenoid in the timer allowing the refrigeration cycle to begin again.
5. The evaporator heaters are off. If the termination thermostat fails to close, the fail-safe set on the timer will terminate defrost.
6. The low pressure control closes and the compressor will start.
7. When the coil temperature reaches 23°F to 30°F, the fan delay closes. This allows the current to flow to the fan motors. The fan motors start running.
8. The system will now operate in the refrigeration cycle until another defrost period is initiated by the timer.

## Electric Defrost Troubleshooting

The electric defrost units are relatively simple and trouble-free in operation:

### Timer

If the system does not go through its proper sequence, check timer operation through a defrost cycle. Check for loose wires or terminals. Before replacing timer, check other components.

### Operation of Paragon Timer

To set time of day grasp knob which is in the center of the inner (fail-safe) dial and rotate it in a counter-clockwise direction. This will cause the outer (24 hour) dial to revolve. Line up the correct time of day on the outer dial with the time pointer. Do not try to set the time control by grasping the other (24 hour) dial. Place pins in the outer dial at the time of day that defrost is required.

### Operation of Grasslin Timer

To set the time, turn the minute hand clockwise until the time of day (and AM or PM) on the outer dial is aligned with the triangle marker on the inner dial. **Do not rotate minute hand counter-clockwise.** Move the white tab (tripper) on the outer dial outward at each desired initiation time. Each white tab (tripper) is a 15 minute interval and provides 15 minutes of defrost. For longer defrost duration, move additional tabs (following in time) from the initiation tab. For example, if a 45 minute defrost is to start at 7:00 AM, move the tabs outward that lie between 7:00 - 7:15, 7:15 - 7:30 and 7:30 - 7:45 on the AM side of the dial. The defrost will initiate at 7:00 AM and time terminate at 7:45 AM (if temperature termination does not occur first). For models with plastic cover on timer assembly; re-install cover after adjustment.

#### NOTE:

After correcting faulty condition it is essential that the coil and unit be free of ice before placing unit back on automatic operation.

#### NOTES:

1. Lockout relays or normally closed switch of auxiliary contact on the compressor contactor may be wired to defrost contactor. Its purpose is to prevent energizing of the defrost heaters until the compressor has pumped down and stopped, thus keeping power demand to a minimum.
2. If the control voltage is to remain energized for any period of time with the compressor disabled, remove the defrost clock pins to prevent the defrost heaters from energizing.
3. A Preventative Maintenance schedule should be set up as soon as possible after start-up to maintain equipment integrity.

**Table 10. System Troubleshooting Chart**

<b>PROBLEM</b>	<b>POSSIBLE CAUSES</b>	<b>POSSIBLE CORRECTIVE STEPS</b>
Compressor will not run	<ol style="list-style-type: none"> <li>1. Main switch open.</li> <li>2. Fuse blown.</li> <li>3. Thermal overloads tripped.</li> <li>4. Defective contactor or coil.</li> <li>5. System shut down by safety devices.</li> <li>6. No cooling required.</li> <li>7. Liquid line solenoid will not open.</li> <li>8. Motor electrical trouble.</li> <li>9. Loose wiring.</li> <li>10. Phase loss monitor inoperative.</li> </ol>	<ol style="list-style-type: none"> <li>1. Close switch.</li> <li>2. Check electrical circuits and motor winding for shorts or grounds. Investigate for possible overloading. Replace fuse after fault is corrected.</li> <li>3. Overloads are automatically reset. Check unit closely when unit comes back on line.</li> <li>4. Repair or replace.</li> <li>5. Determine type and cause of shutdown and correct it before resetting safety switch.</li> <li>6. None. Wait until calls for cooling.</li> <li>7. Repair or replace coil.</li> <li>8. Check motor for open windings, short circuit or burn out.</li> <li>9. Check all wire junctions. Tighten all terminal screws.</li> <li>10. Refer to page 17.</li> </ol>
Compressor noisy or vibrating	<ol style="list-style-type: none"> <li>1. Flooding of refrigerant into crankcase.</li> <li>2. Improper piping support on suction or liquid line.</li> <li>3. Worn compressor.</li> <li>4. Scroll compressor rotation reversed.</li> </ol>	<ol style="list-style-type: none"> <li>1. Check setting of expansion valves.</li> <li>2. Relocate, add or remove hangers.</li> <li>3. Replace.</li> <li>4. Rewire for phase change.</li> </ol>
High discharge pressure	<ol style="list-style-type: none"> <li>1. Non-condensables in system.</li> <li>2. System overcharges with refrigerant.</li> <li>3. Discharge shutoff valve partially closed.</li> <li>4. Fan not running.</li> <li>5. Head pressure control setting.</li> <li>6. Dirty condenser coil.</li> </ol>	<ol style="list-style-type: none"> <li>1. Remove the non-condensables.</li> <li>2. Remove excess.</li> <li>3. Open valve.</li> <li>4. Check electrical circuit.</li> <li>5. Adjust.</li> <li>6. Clean.</li> </ol>
Low discharge pressure	<ol style="list-style-type: none"> <li>1. Faulty condenser temperature regulation.</li> <li>2. Suction shutoff valve partially closed.</li> <li>3. Insufficient refrigerant in system.</li> <li>4. Low suction pressure.</li> <li>5. Variable head pressure valve.</li> </ol>	<ol style="list-style-type: none"> <li>1. Check condenser control operation.</li> <li>2. Open valve.</li> <li>3. Check for leaks. Repair and add charge.</li> <li>4. See corrective steps for low suction pressure.</li> <li>5. Check valve setting.</li> </ol>
High suction pressure	<ol style="list-style-type: none"> <li>1. Excessive load.</li> <li>2. Expansion valve overfeeding.</li> </ol>	<ol style="list-style-type: none"> <li>1. Reduce load or add additional equipment.</li> <li>2. Check remote bulb. Regulate superheat.</li> </ol>
Low suction pressure	<ol style="list-style-type: none"> <li>1. Lack of refrigerant.</li> <li>2. Evaporator dirty or iced.</li> <li>3. Clogged liquid line filter drier.</li> <li>4. Clogged suction line or compressor suction gas strainers.</li> <li>5. Expansion valve malfunctioning.</li> <li>6. Condensing temperature too low.</li> <li>7. Improper TXV.</li> </ol>	<ol style="list-style-type: none"> <li>1. Check for leaks. Repair and add charge.</li> <li>2. Clean.</li> <li>3. Replace cartridge(s).</li> <li>4. Clean strainers.</li> <li>5. Check and reset for proper superheat.</li> <li>6. Check means for regulating condensing temperature.</li> <li>7. Check for proper sizing.</li> </ol>
Little or no oil pressure	<ol style="list-style-type: none"> <li>1. Clogged suction oil strainer.</li> <li>2. Excessive liquid in crankcase.</li> <li>3. Low oil pressure safety switch defective.</li> <li>4. Worn oil pump.</li> <li>5. Oil pump reversing gear stuck in wrong position.</li> <li>6. Worn bearings.</li> <li>7. Low oil level.</li> <li>8. Loose fitting on oil lines.</li> <li>9. Pump housing gasket leaks.</li> </ol>	<ol style="list-style-type: none"> <li>1. Clean.</li> <li>2. Check crankcase heater. Reset expansion valve for higher superheat. Check liquid line solenoid valve operation.</li> <li>3. Replace.</li> <li>4. Replace.</li> <li>5. Reverse direction of compressor rotation.</li> <li>6. Replace compressor.</li> <li>7. Add oil and/or through defrost.</li> <li>8. Check and tighten system.</li> <li>9. Replace gasket.</li> </ol>
Compressor loses oil	<ol style="list-style-type: none"> <li>1. Lack of refrigerant.</li> <li>2. Excessive compression ring blow by.</li> <li>3. Refrigerant flood back.</li> <li>4. Improper piping or traps.</li> </ol>	<ol style="list-style-type: none"> <li>1. Check for leaks and repair. Add refrigerant.</li> <li>2. Replace compressor.</li> <li>3. Maintain proper superheat at compressor.</li> <li>4. Correct piping.</li> </ol>
Compressor thermal protector switch open	<ol style="list-style-type: none"> <li>1. Operating beyond design conditions.</li> <li>2. Discharge valve partially shut.</li> <li>3. Blown valve plate gasket.</li> <li>4. Dirty condenser coil.</li> <li>5. Overcharged system.</li> </ol>	<ol style="list-style-type: none"> <li>1. Add components to bring conditions within acceptable limits (i.e., CPR/EPR valves, additional condenser surface, liquid injection, etc.).</li> <li>2. Open valve.</li> <li>3. Replace gasket.</li> <li>4. Clean coil.</li> <li>5. Reduce charge.</li> </ol>

## Preventive Maintenance

### Unit Coolers

At every six month interval, or sooner if local conditions cause clogging or fouling of air passages through the finned surface, the following items should be checked.

#### 1) Visually inspect unit

- Look for signs of corrosion on fins, cabinet, copper tubing and solder joints.
- Look for excessive or unusual vibration for fan blades or sheet metal panels when in operation. Identify fan cell(s) causing vibration and check motor and blade carefully.
- Look for oil stains on headers, return bends, and coil fins. Check any suspect areas with an electronic leak detector.
- Check drain pan to insure that drain is clear of debris, obstructions or ice buildup and is free draining.

#### 2) Clean evaporator coil and blades

- Periodic cleaning can be accomplished by using a brush, pressurized water or a commercially available evaporator coil cleaner or mild detergent. Never use an acid based cleaner. Follow label directions for appropriate use. Be sure the product you use is approved for use in your particular application.
- Flush and rinse coil until no residue remains.
- Pay close attention to drain pan, drain line and trap.

#### 3) Check the operation of all fans and ensure airflow is unobstructed

- Check that each fan rotates freely and quietly. Replace any fan motor that does not rotate smoothly or makes an unusual noise.
- Check all fan set screws and tighten if needed.
- Check all fan blades for signs of stress or wear. Replace any blades that are worn, cracked or bent.
- Verify that all fan motors are securely fastened to the motor rail.
- Lubricate motors if applicable.

#### 4) Inspect electrical wiring and components

- Visually inspect all wiring for wear, kinks, bare areas and discoloration. Replace any wiring found to be damaged.
- Verify that all electrical and ground connections are secure, tighten if necessary.
- Check operation/calibration of all fan cycle and defrost controls when used.
- Look for abnormal accumulation of ice patterns and adjust defrost cycles accordingly
- Compare actual defrost heater amp draw against unit data plate.
- Visually inspect heaters to ensure even surface contact with the coil. If heaters have crept, decrease defrost termination temperature and be sure you have even coil frost patterns. Re-align heaters as needed.
- Check drain line heat tape for proper operation (supplied and installed by others).

#### 5) Refrigeration Cycle

- Check unit cooler superheat and compare reading for your specific application
- Visually inspect coil for even distribution

### Air-Cooled Condensing Units

#### Quarterly

#### 1) Visually inspect unit

- Look for signs of oil stains on interconnection piping and condenser coil. Pay close attention to areas around solder joints, building penetrations and pipe clamps. Check any suspect areas with an electronic leak detector. Repair any leaks found and add refrigerant as needed.
- Check condition of moisture indicator/sightglass in the sight glass if so equipped. Replace liquid line drier if there is indication of slight presence of moisture. Replace refrigerant, oil and drier if moisture concentration is indicated to be high.

- Check moisture indicator/sightglass for flash gas. If found check entire system for refrigerant leaks and add refrigerant as needed after repairing any leaks.
- Check compressor sightglass (if equipped) for proper oil level.
- Check condition of condenser. Look for accumulation of dirt and debris (clean as required).
- Check for unusual noise or vibration. Take corrective action as required.
- Inspect wiring for signs of wear or discoloration and repair if needed.
- Check and tighten all flare connections.

#### Semi-Annually

#### 2) Repeat all quarterly inspection items.

#### 3) Clean condenser coil and blades

- Periodic cleaning can be accomplished by using a brush, pressurized water and a commercially available foam coil cleaner. If foam cleaner is used, it should not be an acid based cleaner. Follow label directions for appropriate use.
- Rinse until no residue remains.

#### 4) Check operation of condenser fans

- Check that each fan rotates freely and quietly. Replace any fan motor that does not rotate smoothly or makes excessive noise.
- Check all fan blade set screws and tighten as required.
- Check all fan blades for signs of cracks, wear or stress. Pay close attention to the hub and spider. Replace blades as required.
- Verify that all motors are mounted securely.
- Lubricate motors if applicable. Do not lubricate permanently sealed, ball bearing motors.

#### 5) Inspect electrical wiring and components

- Verify that all electrical and ground connections are secure, tighten as required.
- Check condition of compressor and heater contactors. Look for discoloration and pitting. Replace as required.
- Check operation and calibration of all timers, relays pressure controls and safety controls.
- Clean electrical cabinet. Look for signs of moisture, dirt, debris, insects and wildlife. Take corrective action as required.
- Verify operation of crankcase heater by measuring amp draw.

#### 6) Check refrigeration cycle

- Check suction, discharge and net oil pressure readings. If abnormal take appropriate action.
- Check operation of demand cooling, liquid injection or unloaders if so equipped.
- Check pressure drop across all filters and driers. Replace as required.
- Verify that superheat at the compressor conforms to specification. (30°F to 45°F)
- Check pressure and safety control settings and verify proper operation.

#### Annually

#### 7) In addition to quarterly and semiannual maintenance checks, submit an oil sample for analysis

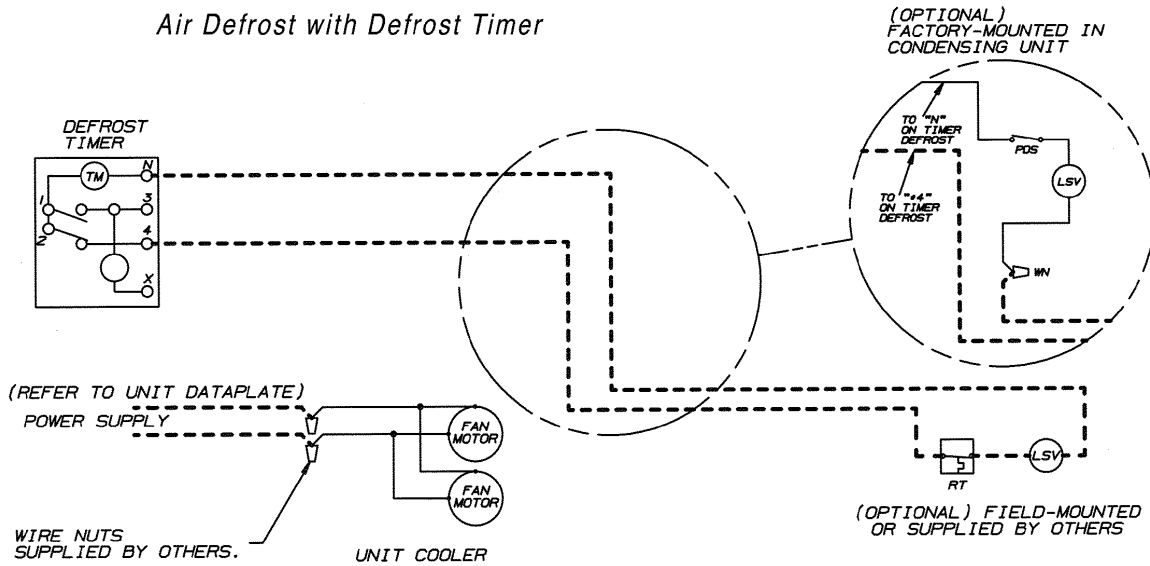
- Look for high concentrations of acid or moisture. Change oil and driers until test results read normal.
- Investigate source of high metal concentrations, which normally are due to abnormal bearing wear. Look for liquid refrigerant in the crankcase, low oil pressure or low superheat as a possible source.

#### 8) Inspect suction accumulator (if equipped)

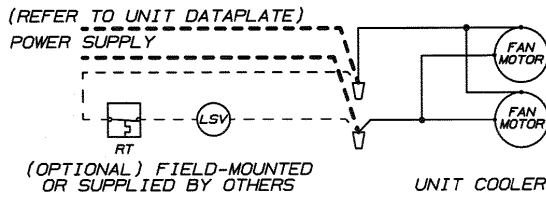
- If the accumulator is insulated remove insulation and inspect for leaks and corrosion.
- Pay close attention to all copper to steel brazed connections
- Wire brush all corroded areas and peeling paint.
- Apply an anticorrosion primer and paint as required. Re-insulate if applicable.

**Diagram 3. Typical Wiring Diagram for Single Evaporator with and without Defrost Timer**

*Air Defrost with Defrost Timer*



*Air Defrost without Defrost Timer*

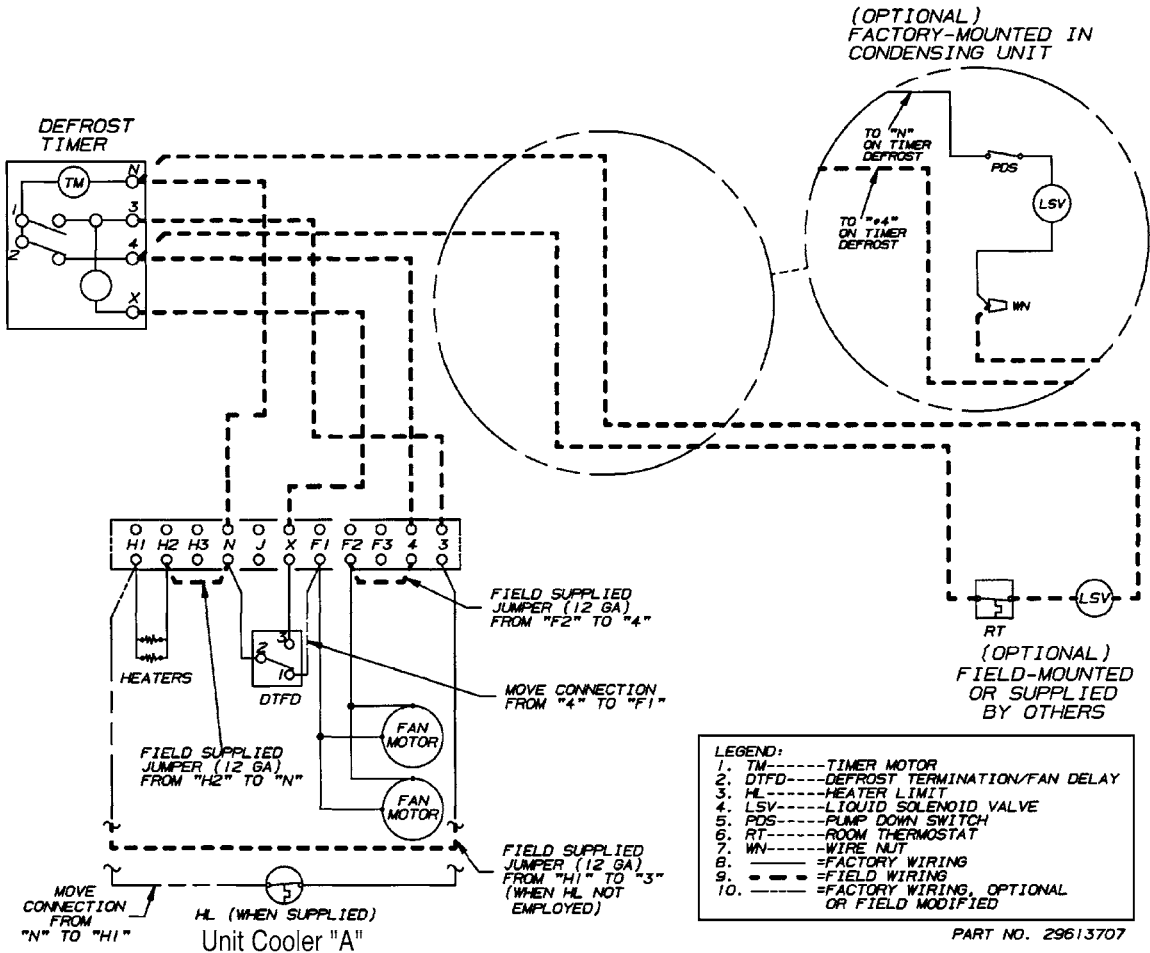


LEGEND:

1. TM-----TIMER MOTOR
2. LSV-----LIQUID SOLENOID VALVE
3. PDS-----PUMP DOWN SWITCH
4. RT-----ROOM THERMOSTAT
5. WN-----WIRE NUT
6. -----FACTORY WIRING
7. -----FIELD WIRING

PART NO. 29613714

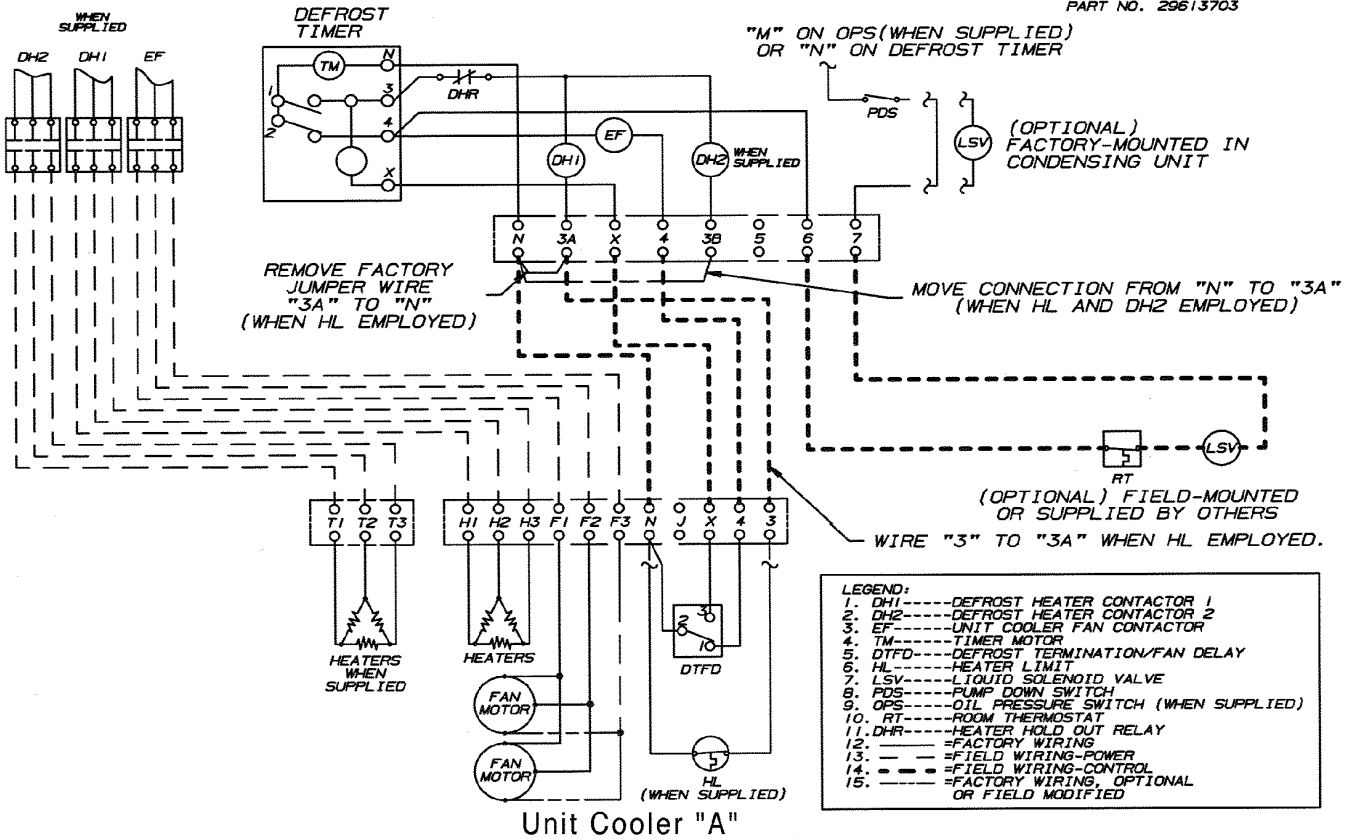
**Diagram 4. Typical Wiring Diagram for Single Evaporator with Defrost Timer Only**





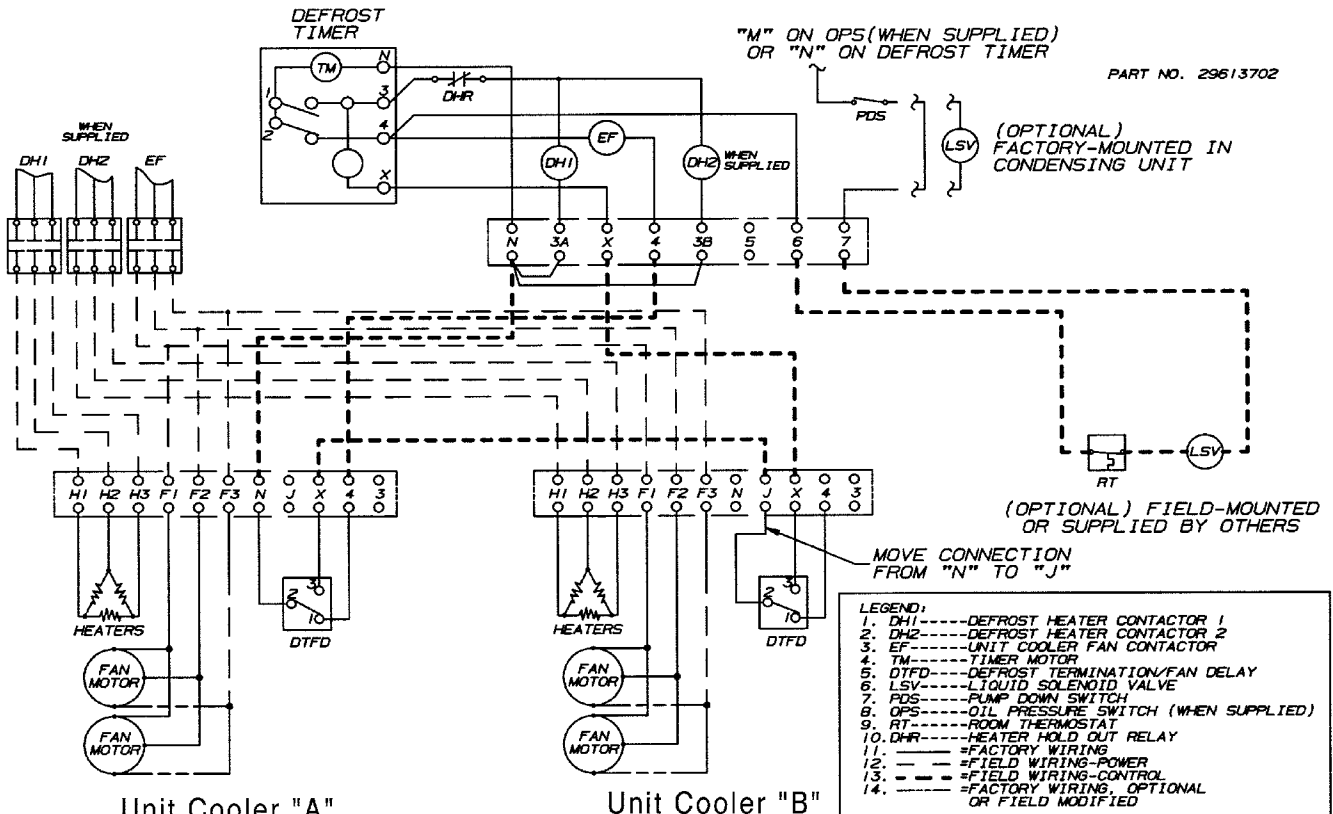
**Diagram 7. Typical Wiring Diagram for Single Evaporator Defrost and Evaporator Fan Contactors**

PART NO. 29613703

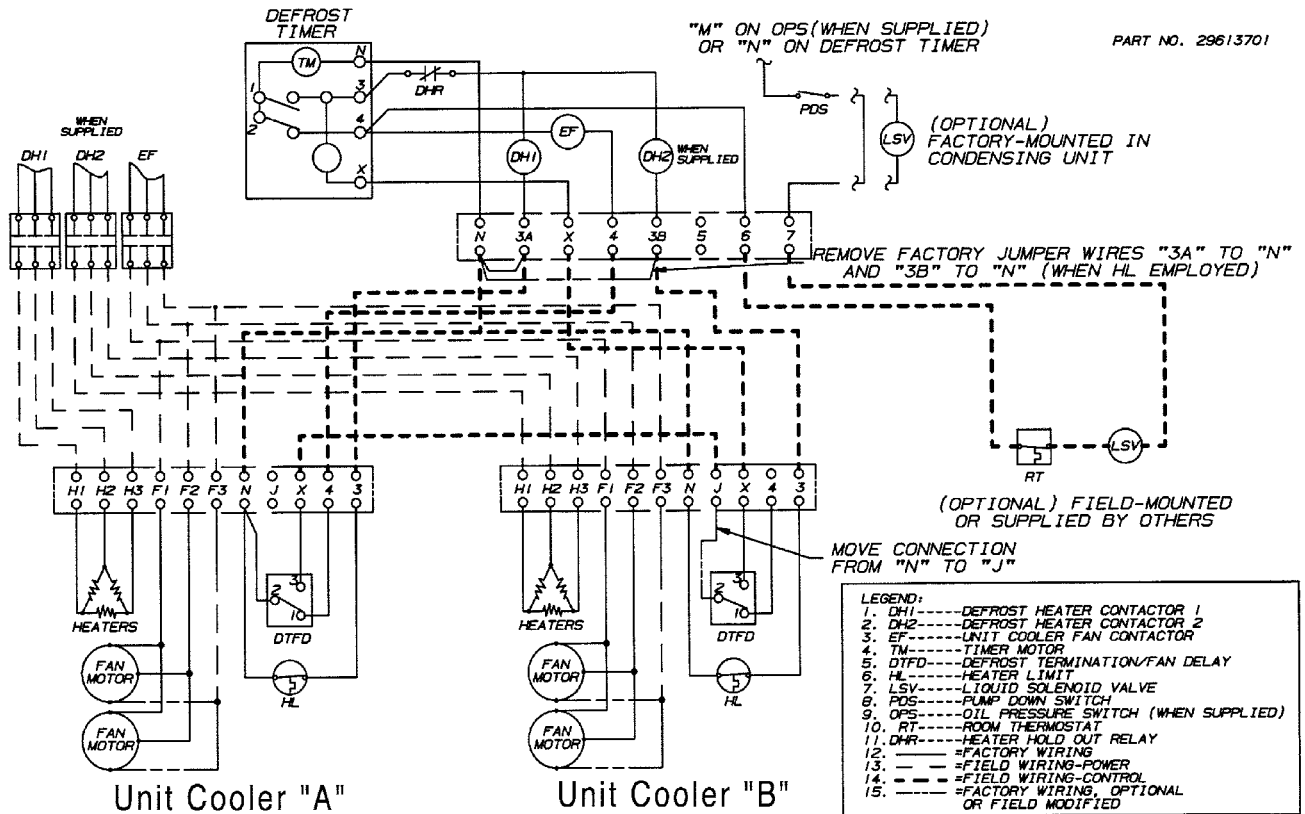


**Diagram 8. Typical Wiring Diagram for Multiple Evaporators with Evaporator Fan Contactors/without Heater Limit Defrost**

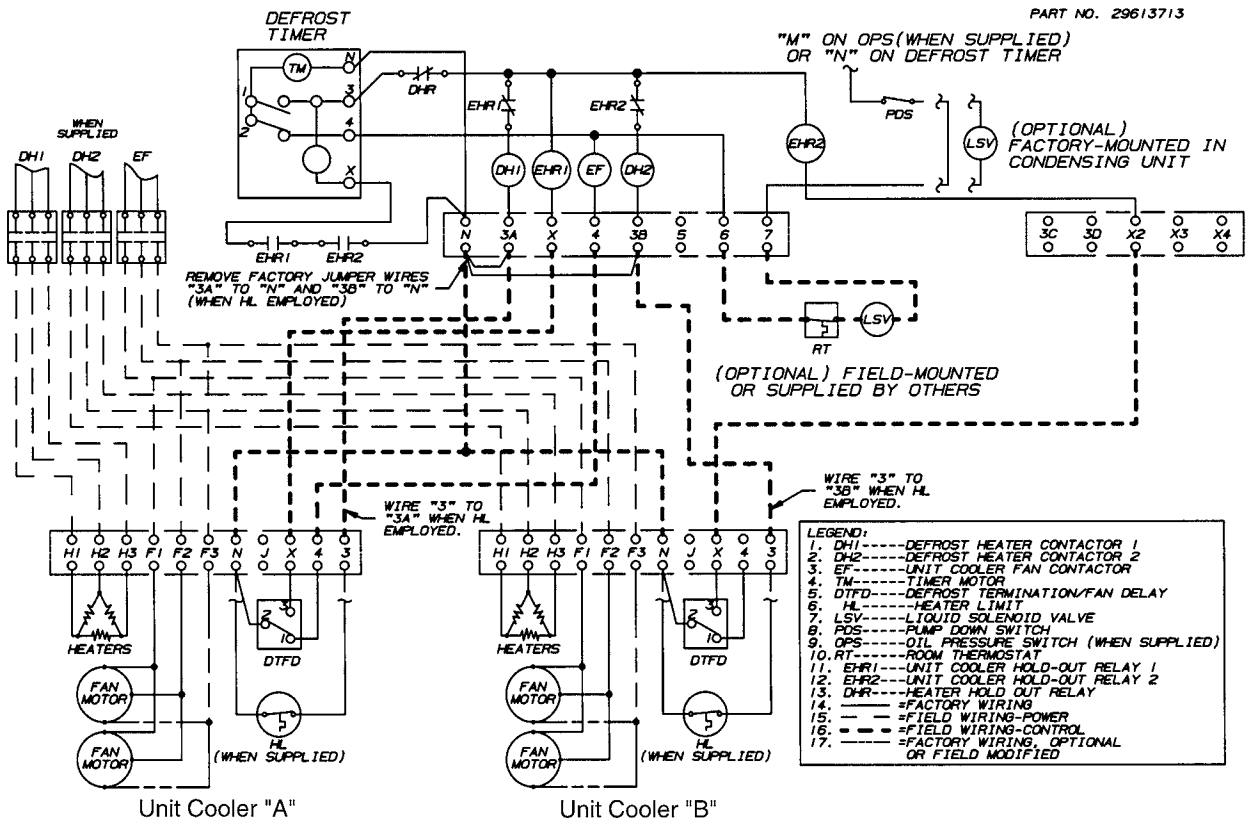
PART NO. 29613702



**Diagram 9. Typical Wiring Diagram for Multiple Evaporators with Heater Limit Defrost and Evaporator Fan Contactors**



**Diagram 10. Typical Wiring Diagram for Multiple Evaporators Defrost and Evaporator Fan Contactors with Unit Cooler Holdout Relay**



Replacement Parts by



InterLink™ Commercial Refrigeration Parts is your link to a complete line of dependable and certified commercial refrigeration parts, accessories and innovative electronic controls for all Heatcraft Refrigeration Products (HRP) brands - including Bohn, Larkin, Climate Control and Chandler. At InterLink, we provide our wholesalers with a comprehensive selection of product solutions and innovative technologies for the installed customer base. And every product is built to ensure the same high performance standards with which all HRP brands are built — backed by a dedicated team to serve every customer need, delivering at the best lead times in the industry.

Replacement parts should be obtained from your local InterLink wholesaler. Replacement parts, which are covered under the terms of the warranty statement on page 2 of this manual, will be reimbursed for total part cost only. The original invoice from the parts supplier must accompany all warranty claims for replacement part reimbursement. Heatcraft Refrigeration Products reserves the right to adjust the compensation amount paid on any parts submitted for warranty reimbursement when a parts supplier's original invoice is not provided with a claim. **For more information, call 800-686-7278 or visit [www.interlinkparts.com](http://www.interlinkparts.com).**

**For our complete Refrigeration Systems Installation and Operations Manual (H-IM-64L),  
please visit <http://heatcraftprd.com/service/publibrary.asp>.**

Since product improvement is a continuing effort, we reserve the right to make changes in specifications without notice.

The name behind the brands you trust.™ 